

Process Heaters

Air Heaters

Ceramic Infrared Heaters



OSRAM SYLVANIA Turns Up The Heat!

1 If you need to seal, melt, bond, cure, dry, cut, solder

OSRAM SYLVANIA can help you do it faster, cleaner, in less space, more economically and with more control.

Since the introduction of our patented Serpentine Coil Heater in 1968, OSRAM SYLVANIA has created effective process heat solutions for industry. You can install OSRAM SYLVANIA process heaters with confidence, knowing they are engineered to do the job and are manufactured to the toughest standards we can apply.

High Quality

Each process heater, system, and accessory is manufactured to exacting world class levels. We are an ISO 9002 company and have CE certified products.

Quick Response

Our focus is to have the fastest cycle time from customer inquiry to delivery of the product.

Low Cost

At OSRAM SYLVANIA, we strive to be the low cost producer to provide our

customers competitive pricing and high value.

Ongoing Innovation

Through research and development and access to the power of global networking, you will find working with OSRAM SYLVANIA will help drive your products to the leading edge of your market.

Hot air to 1600°F

OSRAM SYLVANIA Process Air Heaters are ideal for use in a variety of industrial processes including sealing, melting, bonding, drying, curing and soldering. Hot air is ideal for heating complex shapes, or when space is limited. Sylvania's unique Serpentine Coil element design is

extremely compact and energy efficient.

With a good control system OSRAM SYLVANIA Process Air Heaters are precisely controllable to $\pm 1^\circ\text{F}$, ensuring your product and process remains consistent. In addition, the SureHeat™ 36,000, Hot Air System, and G-Temp have

special technology that protects the element against burnout due to loss of airflow or excess voltage.

OSRAM SYLVANIA Process Air Heaters should be controlled with phase angle fired SCR (silicon controlled rectifier) or approved SSR (solid state relay) power controls.

Radiant heat to 1400°F

OSRAM SYLVANIA Ceramic Infrared Heaters provide a highly efficient radiant heat source for a variety of applications including thermoforming plastics, drying inks and paper, warming food, and drying textiles.

OSRAM SYLVANIA Ceramic Infrared Heaters are coated with a special glaze that changes color from rose to gray during operation. This special feature helps to identify end-of-life heaters within a large array.

Regardless of your heater needs, OSRAM SYLVANIA and our worldwide network of Process Heat distributors can put our experience to work for you!

Table of Contents

Products	2
Applications.	3
About Air Heaters	5
Air Heaters	7-22
Ceramic Infrared Heaters	23-28
Reference Data	29

Products

Application	Product	kW	Max. Air Pressure (psi)	Key Features	Page
Low kW Low Flow ↓	Series I, II, III	0.6 - 2.4	7	Basic heater with quartz insulator tube.	7
	Hot Air Tool	1.5 - 3.5	60	Built in "K" thermocouple.	9
	G-temp	1.5 - 3.0	2	Built-in manual control with burnout protection. Good for use with blowers.	11
	Serpentine II	2.0 - 3.6	25	Triple pass exchanger housing.	13
	Serpentine VI	5.0 - 8.0	25	Triple pass exchanger housing.	13
	Threaded Inline	1.6 - 18.0	150	For high-pressure applications.	15
	Hot Air System	3.0 - 8.0	100	Complete heating system with controls. Includes burnout protection system.	17
	SureHeat™ 36,000	6.0 - 36.0	10	New burnout protection system. Good for use with blowers.	19
High kW High Flow	Flanged Inline	36.0 - 192.0	150	For high-pressure, high-flow applications. Includes burnout protection system.	21
Radiant Heating	Ceramic Infrared Heaters	0.1 - 1.0	N/A	Rose glaze changes color to gray during operation.	23



Applications

3

OSRAM SYLVANIA Heaters are used throughout the world in varying industries such as packaging, plastics, semiconductor, electronics, rubber, medical, pharmaceutical, and printing.

Packaging:

- High speed poly sealing
- High speed/compact heat shrink installations
- Forming

Plastics/Rubber:

- Forming and welding plastic sheet, tube, and rod
- Thermoforming
- Vacuum forming
- Curing extruded parts
- Drying
- Laminating

Textiles:

- Texturing fibers, drying cloth
- Drying dyed/printed fabric
- Curing latex coatings

Soldering/Brazing:

- Single or multiple station soldering operations

Semiconductor and Electronics:

- Air knife in wave solder machines
- Soldering/desoldering PC boards, lead frames, capacitors
- Multi-station desoldering of surface mount devices from one central heat source
- Wafer and PC board drying
- Heat shrinking wire insulation
- Preheating process gases
- Preheat PCBs
- IR reflow ovens for SMT

Industry Drying Processes:

- Curing and drying resins, lacquers and related products

Sterilization:

- Pharmaceuticals
- Medical/surgical hardware
- Packaging materials

Chemical Processing:

- In-line heating of air or inert gases

Food

- Warming
- Baking

Paper

- Speed drying coated paper
- Adhesive activation

Wood/Furniture

- Heating bonded/painted/plastic coated components
- Drying same components

Ceramic

- Drying glazes/pigments

Paint

- Drying lacquers/finishes
- Baking lacquers/finishes

Printing

- Ink drying

Thin Film Deposition

- Vacuum coating substrates

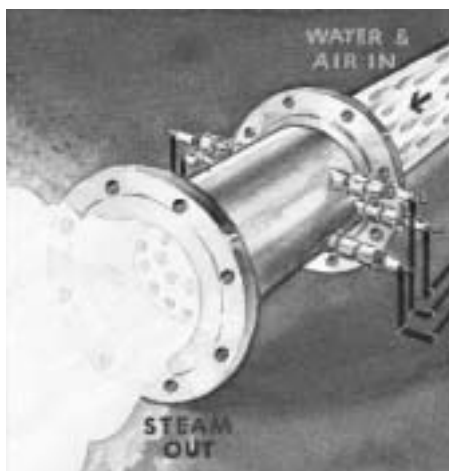
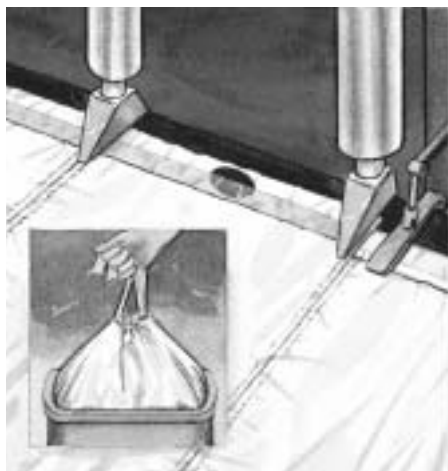

About Air Heaters

5 Selecting an Air Heater

The energy (kW) requirement is calculated from the following formula:

$$KW = \frac{SCFM \times (Texit - Tinlet)}{2500}$$

SCFM = Air flow in Standard* Cubic Feet per Minute
 Tinlet = Inlet Air Temperature (°F) (typically 70°F)
 Texit = Desired Exit Air Temperature (°F)

Example: Heating 10 SCFM from ambient temperature (70°F) to 800°F:

$$KW = \frac{10 \text{ SCFM} \times (800^\circ\text{F} - 70^\circ\text{F})}{2500} = 2.9 \text{ kW}$$

Conversion Formulas:

(Liters per Minute)/28.3 = Cubic Feet per Minute
 °C = 5/9 (°F - 32)
 °F = 9/5°C + 32

**Please refer below for an explanation of Standard flowrate*

Air Sources

If used properly, heater life of 5000 hours or greater can be expected. To ensure long heater life and safe operation, follow these guidelines. Also read and understand your heater Operating Manual before use. Failure to follow these guidelines can result in heater damage, failure, or personal injury.

Air Sources

In general, compressed air, and air from regenerative blowers may be used to supply OSRAM SYLVANIA air heaters. Your air source should be clean and dry. Dirt, grease, oil, or oil vapors, or corrosive or reactive gases will damage an air heater. Also, use air or inert gas only. Do not use with volatile or combustible gases.

Regenerative blowers

Regenerative blowers are compact and inexpensive clean air sources. They can provide large amounts of low-

pressure air for your air heating system. Blower size is based on the maximum amount of airflow (CFM or LPM) it can produce without any inlet or exit restrictions. When a heater or other restriction is attached to a blower, the maximum flow decreases. If the blower is severely restricted, the blower motor can overheat and fail.

When designing your heating system, you should try to minimize air restrictions, and select a blower sufficient to overcome the backpressure generated by the heater, flare, and associated piping.

Because of their small size, the Series, Hot Air Tool, and Serpentine II heaters should not be used with regenerative blowers.

Compressed Air

Compressed air is commonly available in most factories. It is high-pressure regulated air (typically to 100psi), and often contains oil for lubricating pneumatic valves and equipment. You must filter this oil to prevent fouling and damage to OSRAM SYLVANIA's electric air heater elements.

When measuring compressed air flow rates, be sure you are

measuring Standard CFM or Standard LPM units. The "Standard" means that the units are measured at standard temperature and pressure. Many flow meters are labeled SCFM, but this is incorrect at the higher pressures produced by compressed air. For accurate flow measurements, you must consult your flow meter manual for converting CFM to "Standard" CFM. In the diagram below, the flow meter reading (CFM) is converted to SCFM using a Dwyer ball-type flow meter conversion.

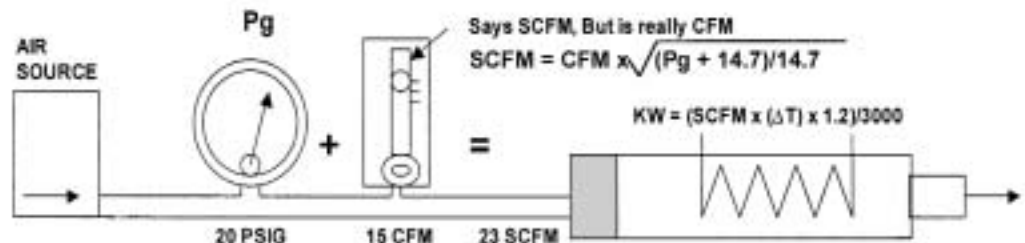

Controls

A good control system is critical for long heater life. Before turning your control system on, you must have sufficient airflow through the heater before applying power. (Applies to heaters without SureHeat or Hot Air System over-temperature protection.) Only qualified individuals should install OSRAM SYLVANIA heaters and controls. Follow all applicable electrical codes and use proper wiring.

Open-Loop (Manual) Control

This simple method of control uses a manually operated power controller to apply a fixed voltage to the heating element. Using this system, the operator manually adjusts the controller to change heater temperature. Note that if the airflow is suddenly interrupted, the element could fail. The open-loop controller is generally used with OSRAM SYLVANIA's Series heaters.

Closed-Loop (Feedback) Control

A closed-loop heater control system uses a power controller, temperature controller, and thermocouple to provide a constant output temperature, regardless of changes in airflow. The temperature controller also provides a convenient display of your process air temperature.

Power Controller

Phase angle fired SCR (Silicon Controlled Rectifier) power controls will provide the smoothest power regulation for OSRAM SYLVANIA Air Heaters.

Other power controls may be suitable, such as distributive zero cross SSR (Solid State Relays) or other fast-switching SSR's, but you should contact OSRAM SYLVANIA for approval before use.

Temperature Controller

Use only digital temperature controls with type-K thermocouple inputs. The temperature control output must match the input of the power control. (i.e. 4-20mA, or 0-10VDC).

A standard PID-type control with a wide proportional band setting will work best to minimize temperature overshoot.

PID parameters may be auto-tuned, but only at temperatures well below the maximum of the heater. If the temperature rises too high during auto-tune, turn power off immediately.

When using a Solid State Relay power control, the temperature controller cycle time should be set for 100ms or less.

Thermocouple

Use only a fine-wire (.030" max wire dia.), exposed-junction, type-K thermocouple placed within 1" of the heater exit for accurate temperature readings. Other thermocouple styles, or varying the distance from the heater exit will result in temperature measurement errors and/or heater failure.

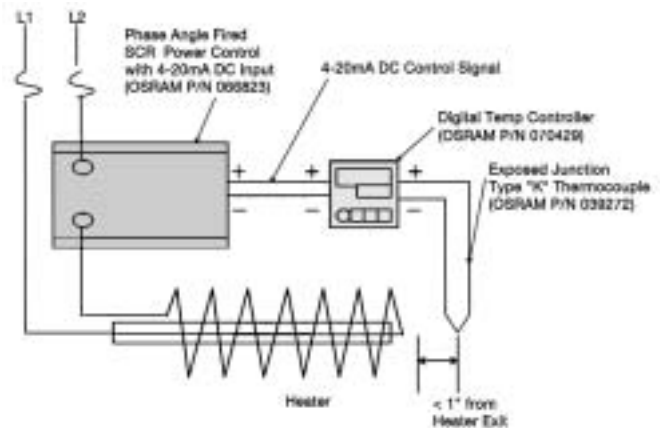

Series I, II, III Heaters

7 Features

- Air temperatures to 1600°F (871°C)
- Quartz outer tube housing.
- Nozzled (Style B) or open-ended (Style A) design
- High-temperature silicone rubber Rear Adapter/ Terminal Assembly
- Maximum air pressure 7 psi
- Maximum inlet temperature 80°F (27°C)



Heater Selection

To determine the proper size heater, plot a point, which defines your required air temperature and flow. The nearest curve to the right and above this point represents the proper heater selection.

All temperature measurements were created using an exposed junction, 1/16" diameter "K" thermocouple.

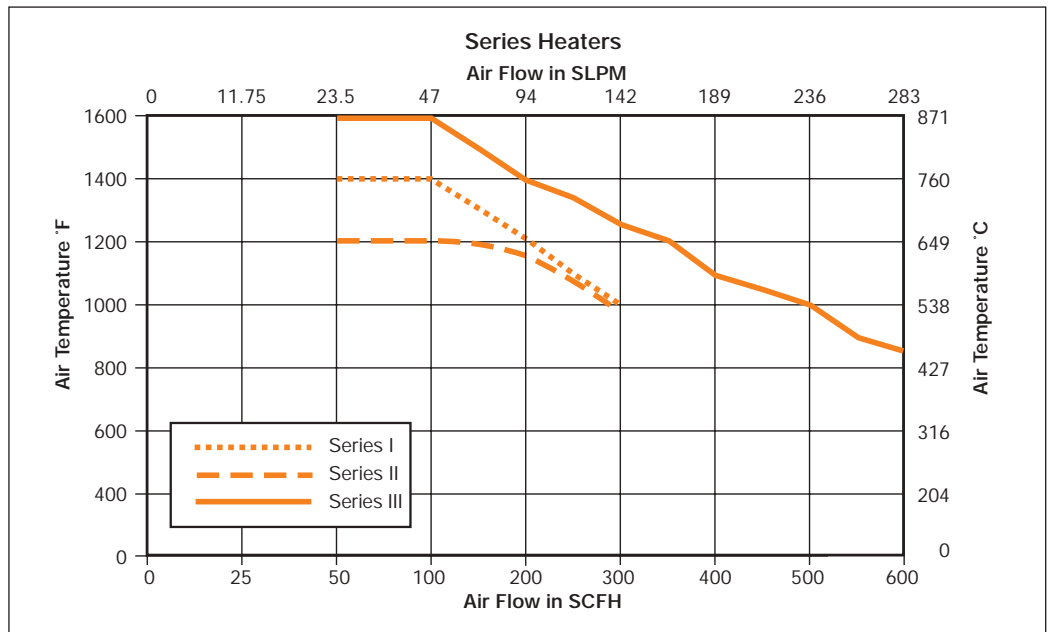

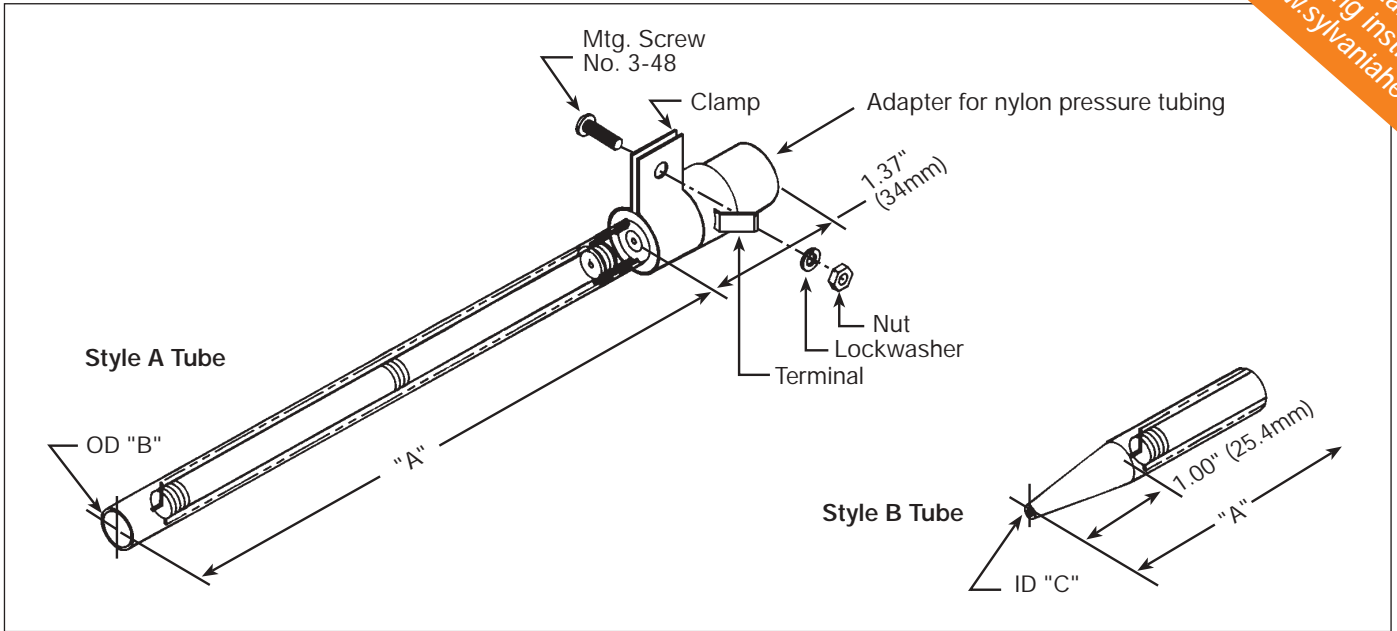

Part Number	Tube Style	Max. Watts	Max. Volts	Tube Length "A"	Tube O.D. "B"	Nozzle I.D. (Style B) "C"
Series I						
010226	A	1050	180	6.875" (174.6mm)	0.410" (10.4mm)	—
014372	A	1000	130	7.750" (196.9mm)	0.410" (10.4mm)	—
014682	B	680	145	7.875" (200.0mm)	0.410" (10.4mm)	0.065" (1.7mm)
Series II						
016501	A	1125	130	3.875" (98.4mm)	0.410" (10.4mm)	—
016503	A	850	80	3.875" (98.4mm)	0.410" (10.4mm)	—
016502	B	600	95	4.875" (123.8mm)	0.410" (10.4mm)	0.065" (1.7mm)
016504	B	650	70	4.875" (123.8mm)	0.410" (10.4mm)	0.065" (1.7mm)
Series III						
017558	A	2050	160	6.875" (174.6mm)	0.594" (15.1mm)	—
017575	B	1450	135	7.875" (200.0mm)	0.594" (15.1mm)	0.115" (2.9mm)

Accessories

Part Number	Description
057081	Open Loop (Manual) power controller 25A
Outer Shields — Open End	
015509	For Series I 014372
017853	For Series II
Outer Shields — Flared	
037261	For Series I 010226, 014682

Hot Air Tools

9

Features

- Air temperatures controllable to 1400°F (760°C)
- Built-in "K" type thermocouple
- High pressure hose barb air connection (for 1/4" hose)
- Maximum inlet temperature 80°F (27°C)
- Maximum air pressure 60 PSI (4Bar)
- Slotted exit for nozzle attachment
- 304 Stainless Steel body
- 3' (914mm) power and thermocouple leads



Heater Selection

To determine the proper size heater, plot a point, which defines your required air temperature and flow. The nearest curve to the right and above this point represents the proper heater selection.

All temperature measurements were created using an exposed junction, 1/16" diameter "K" thermocouple.

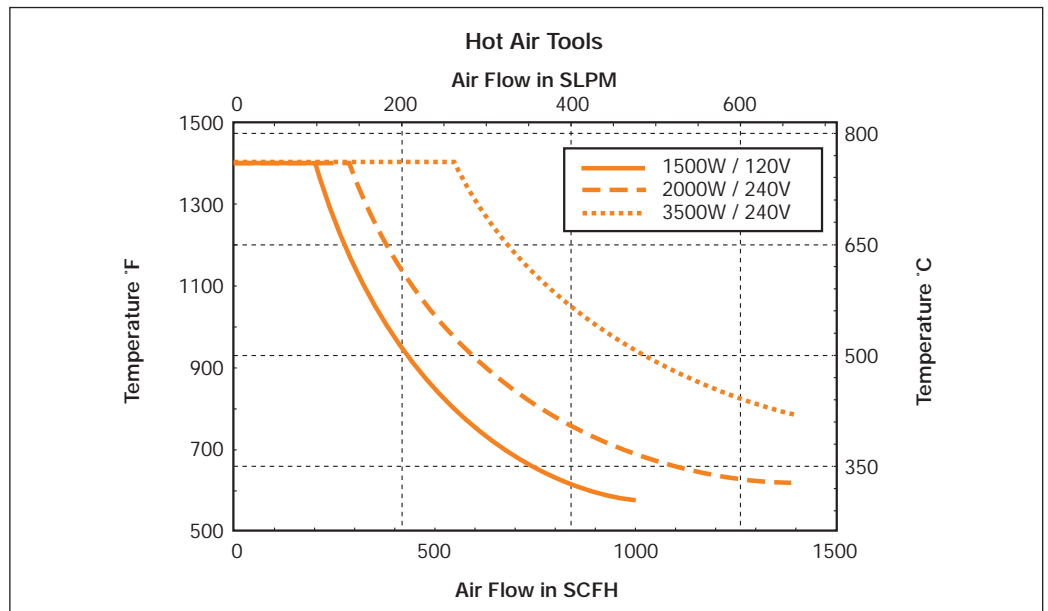

Specifications

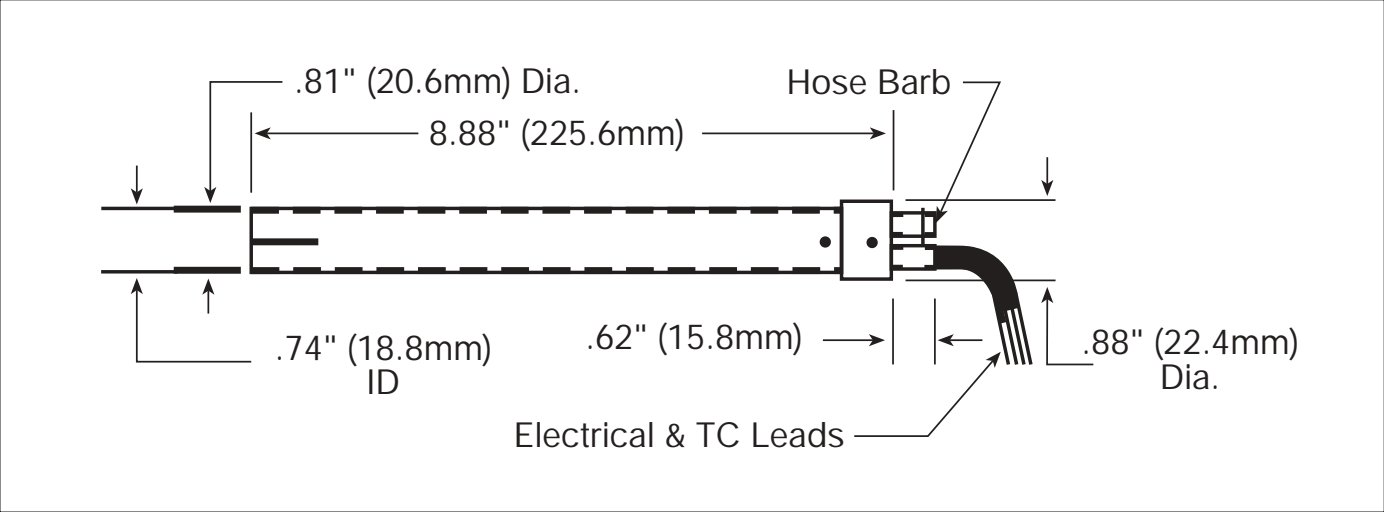

Part Number	Maximum Watts	Maximum Volts	Maximum Amps	Maximum Operating Pressure PSI (mBars)	Minimum Flow SCFH (SLPM)
068462	1500W	120	13	60 (4)	30 (14)
068463	2000W	240	9	60 (4)	70 (33)
068464	3500W	240	15	60 (4)	90 (43)

Accessories

Part Number	Description
068472	Flare (includes clamp) .06" x 2.5" (1.52mm x 63.5mm) opening
057081	Open Loop (manual) Power Control, 25A
066823	Closed Loop Power Control, 30A (used with 070429)
070429	Digital Temperature Control, 1/16 DIN (used with 066823)

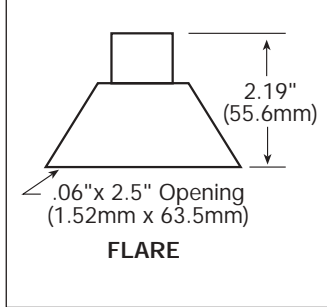

G-Temp® Heaters

11 Features

- Air temperature controllable to 1300° F (704° C)
- Integrated air heater, thermal sensor, and manual potentiometer power controller
- Protection from premature element failure
- Maximum air pressure 2 PSI
- Maximum inlet temperature 100° F (38° C)
- Available in 1500 and 3000 Watt models
- Available in 50 and 60 Hz models
- Built-in air damper



Heater Selection

To determine the proper size heater, plot a point, which defines your required air temperature and flow. The nearest curve to the right and above this point represents the proper heater selection.

All temperature measurements were created using an exposed junction, 1/16" diameter "K" thermocouple.

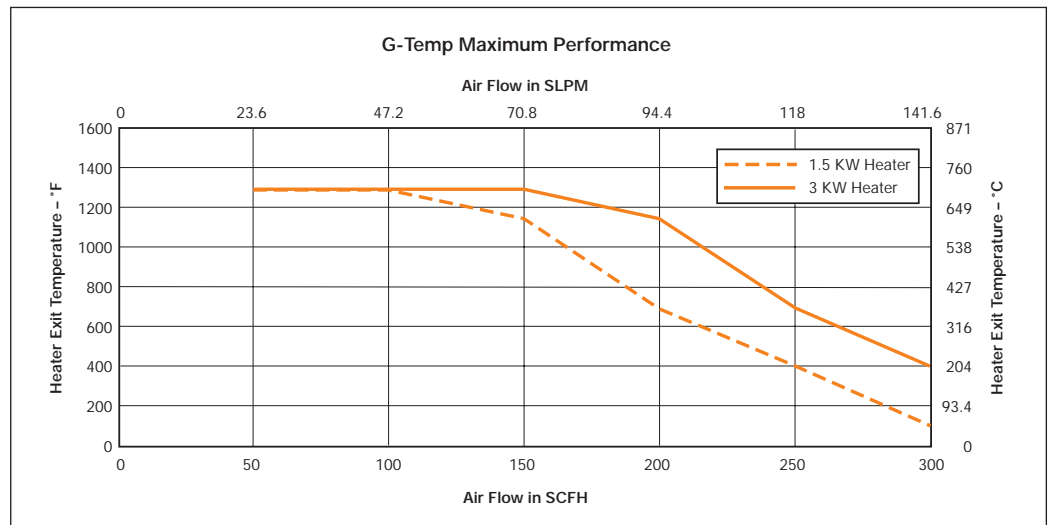

Specifications

For detailed operating instructions, visit www.sylvaniaheaters.com

Part Number	Max. Watts	Max. Volts	Max. Amps	Hz Rating	Replacement Element Part Number
066136	1500	120	13	60	066137
070282	3000	230	15	50	065335
065253	3000	230	15	60	065335

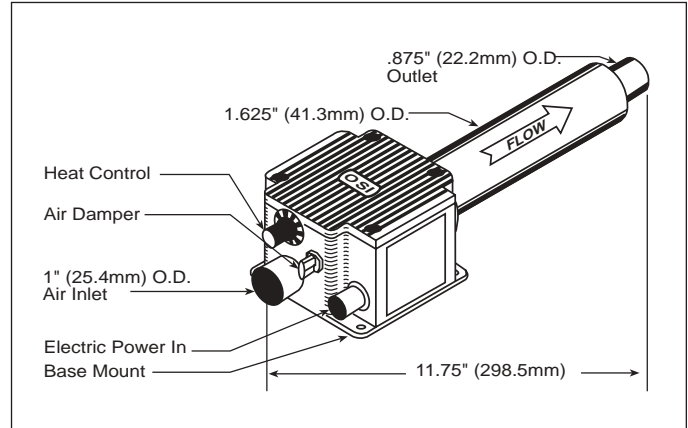

Accessories

Part Number	Description
065503	Regenerative Blower 13.5 SCFM Single Phase 115V or 230V
065507	Regenerative Blower 27.0 SCFM Single Phase 115V or 230V

Serpentine II, VI Triple Pass Heaters

13

Features

- Air temperatures controllable to 1500°F (815°C)
- Serpentine II to 3.6kW
- Serpentine VI to 8.0kW
- Triple Pass Heat Exchanger uses incoming air to cool outer shell and reduce radiant heat losses
- Replaceable element assemblies
- Rapid heat-up and response
- Compact size



Heater Selection

To determine the proper size heater, plot a point, which defines your required air temperature and flow. The nearest curve to the right and above this point represents the proper heater selection.

All temperature measurements were created using an exposed junction, 1/16" diameter "K" thermocouple.

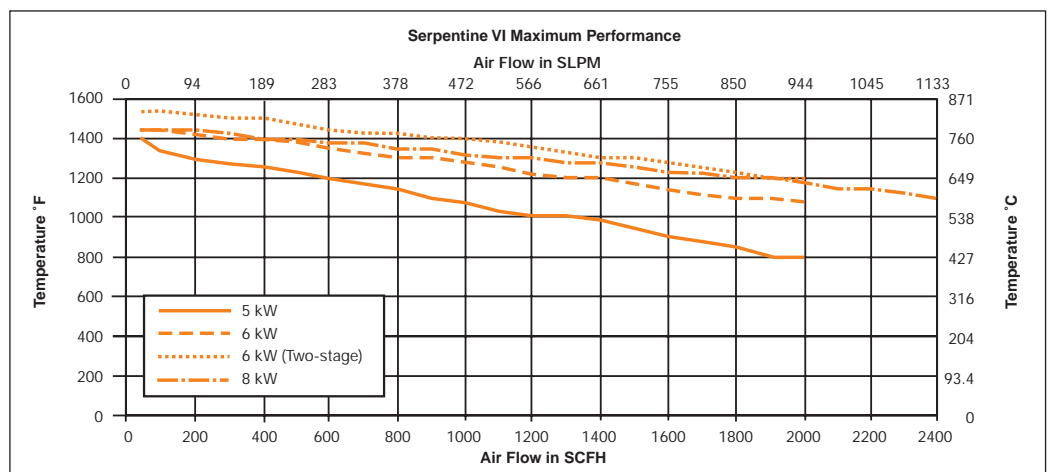
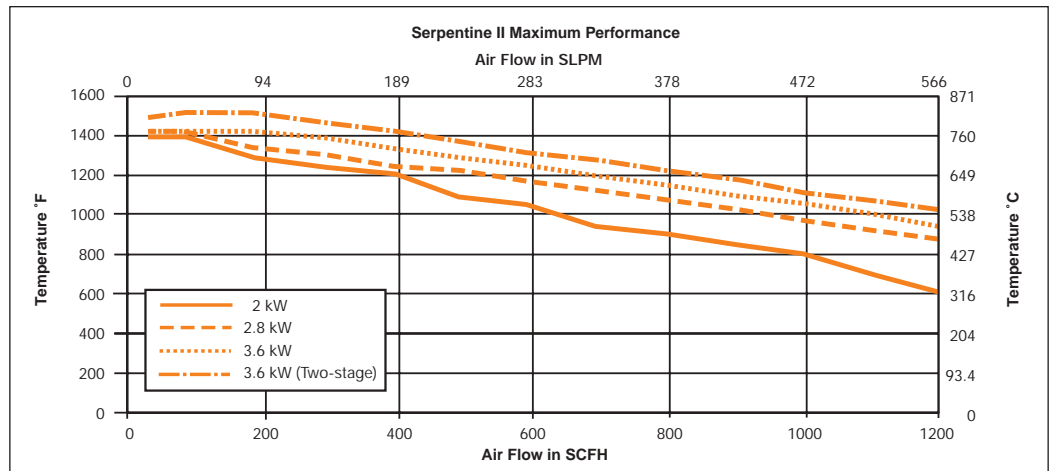

Specifications

For detailed operating instructions, visit www.sylvaniaheaters.com

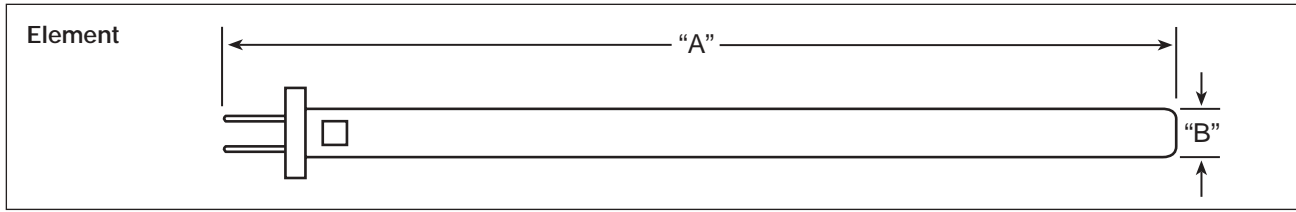

Serpentine II Elements used with housing 029763

Part Number	Max. Watts	Max. Volts	Max. Amps	Max. Inlet Pressure	Length "A"	O.D. "B"
029765	2kW	240	8.3	25 PSI	8.20" (208mm)	0.63" (16mm)
029766	2.8kW	240	11.7	25 PSI	8.20" (208mm)	0.63" (16mm)
029767	3.6kW	240	15	25 PSI	8.20" (208mm)	0.63" (16mm)
060418	3.6kW (Two-stage)	240	15	25 PSI	8.50" (216mm)	0.63" (16mm)

14

Serpentine VI Elements used with housing 057088

Part Number	Max. Watts	Max. Volts	Max. Amps	Max. Inlet Pressure	Length "A"	O.D. "B"
040291	5kW	240	20.8	25 PSI	10.88" (276mm)	1.25" (32mm)
040292	6kW	240	25	25 PSI	10.88" (276mm)	1.25" (32mm)
061429	6kW (Two-stage)	240	25	25 PSI	10.88" (276mm)	1.25" (32mm)
056548	8kW	240	33.3	25 PSI	10.88" (276mm)	1.25" (32mm)

Housing Assemblies

Part Number	Serpentine Type	"A"	"B"	"C"	"D"	"E"
029763	II	1.6" (40mm)	9.0" (229mm)	10.0" (254mm)	0.7" (18mm)	3/8" NPT
057088	VI	2.1" (54mm)	11.9" (302mm)	12.9" (327mm)	1.4" (35mm)	3/4" NPT

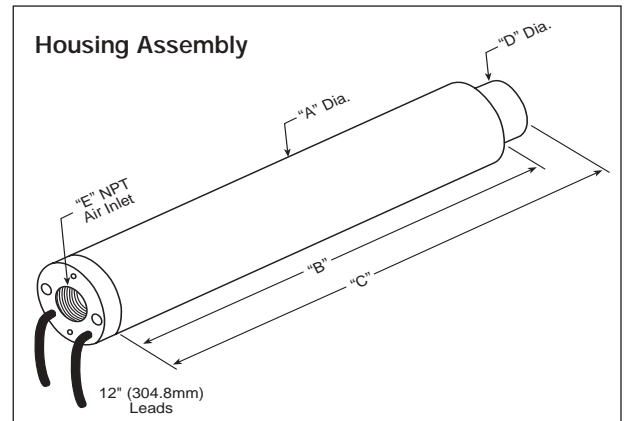

Accessories

Part Number	Description
039739	Serp II base adaptor assembly
042339	Serp VI base adaptor assembly
029485	Serp II TC holder (includes TC)
040299	Serp VI TC holder (includes TC)
041462	Serp II flare (2.5"x.06") with TC port (no TC)

Part Number	Description
057086	Serp II flare (2.5"x.06")
039272	"K" type thermocouple probe
068823	Closed loop power control, 240V, 30A
057081	Open loop (manual) power control, 240V, 25A
070429	Digital temperature controller, 1/16 DIN, 4-20mA

Inline Heaters

15 Features

- Air temperatures to 1400°F (760°C)
- For applications requiring high pressure air
- Available with both ends threaded on 3/8", 1/2", 1-1/4", and 2-1/2" NPT units
- All Stainless Steel housing
- Available with high temperature electrical feedthroughs
- Serpentine Heating Element housed in a quartz or ceramic tube is secured into a stainless steel pipe with threaded ends.



Style A

- Should be used whenever an absolute leak-proof system (up to 150 PSI) is required
- Two high temperature feedthroughs placed 180 degrees apart at the inlet of the heater for electrical connections
- Maximum inlet temperature 900°F

Style B

- Maximum air pressure 150 psi, but will have slight air leakage through power wire strands
- 12" (305mm) long power wires exit at a 90 degree angle from the heater
- Maximum inlet temperatures 200°F

Heater Selection

To determine the proper size heater, plot a point, which defines your required air temperature and flow. The nearest curve to the right and above this point represents the proper heater selection.

All temperature measurements were created using an exposed junction, 1/16" diameter "K" thermocouple.

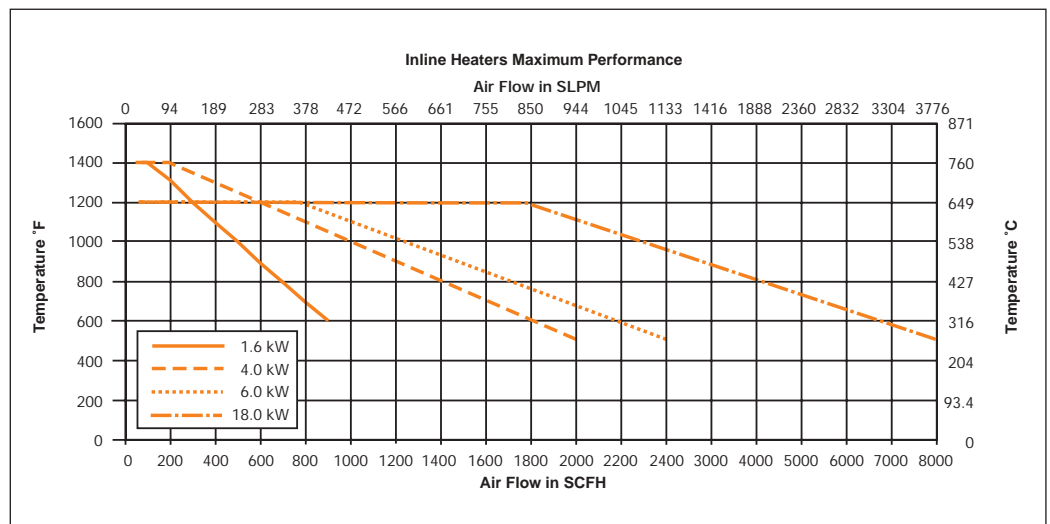

Specifications

For detailed operating instructions, visit www.sylvaniaheaters.com

3/8" THREADED INLINES

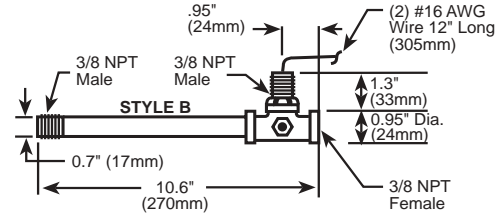
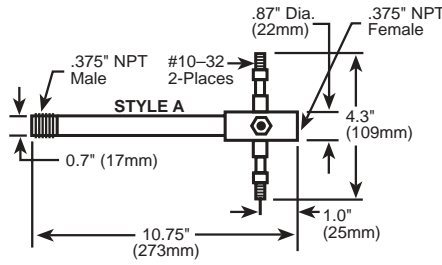

1/2" THREADED INLINES

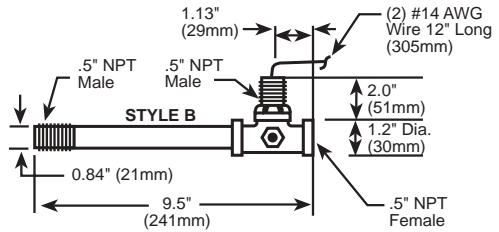
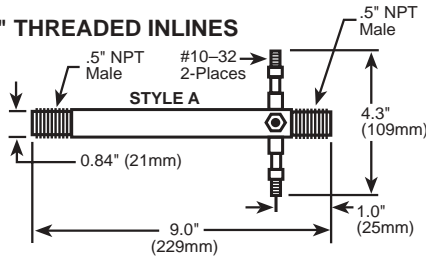

1-1/4" THREADED INLINES

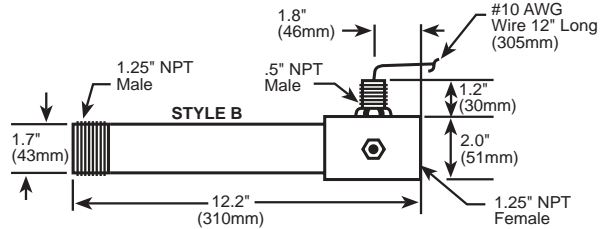
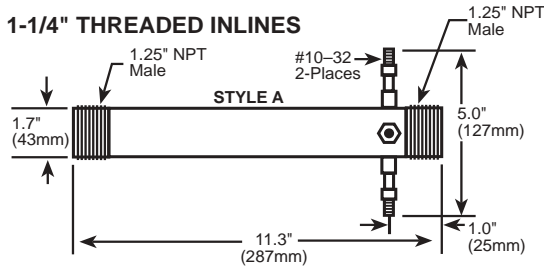

2-1/2" THREADED INLINE

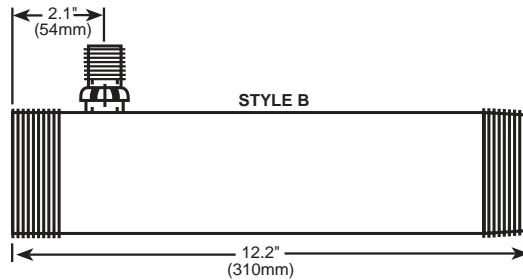
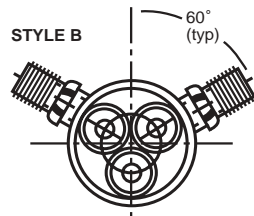

Heater Size (NPT)	Max. Watts	Max. Volts	Max. Amps	Part No., Style A	Part No., Style B
3/8"	1.6kW	170	9.4	038821	038822
1/2"	4.0kW	220	18.2	038823	038824
1-1/4"	6.0kW	220	27.3	038825	038826
2-1/2"	18.0kW	240	75.0 (1ph) / 44.0(3ph)	N/A	063007

Accessories

Part Number	Description
057081	Open loop (manual) power control, 25A
068823	Closed loop power control, 30A
070429	Temperature controller — 1/6 DIN
039272	"K" Type Thermocouple Probe

Hot Air System

17 Features

- Air temperatures to 1400°F (760°C)
- Complete closed loop control system with over-temperature protection
- 304 Stainless Steel housing
- Replaceable element assembly
- Heavy-gauge threaded inlet/exit orifices
- Quick connect polarized electrical plugs
- Single-pass up to 100 PSI
- Triple-pass up to 25 PSI



Dual sensors within the Hot Air System sense both element temperature along the entire length of the heater and ambient temperature at the heater lead connections. These sensors will override any other system input,

thereby preventing the element from overheating or premature element failure. The controller

is preset to limit the maximum operating temperature at either of these sensors, eliminating

the possibility of exceeding the maximum recommended operating temperatures.

Heater Selection

To determine the proper size heater, plot a point, which defines your required air temperature and flow. The

nearest curve to the right and above this point represents the proper heater selection.

All temperature measurements were created using an exposed junction, 1/16" diameter "K" thermocouple.

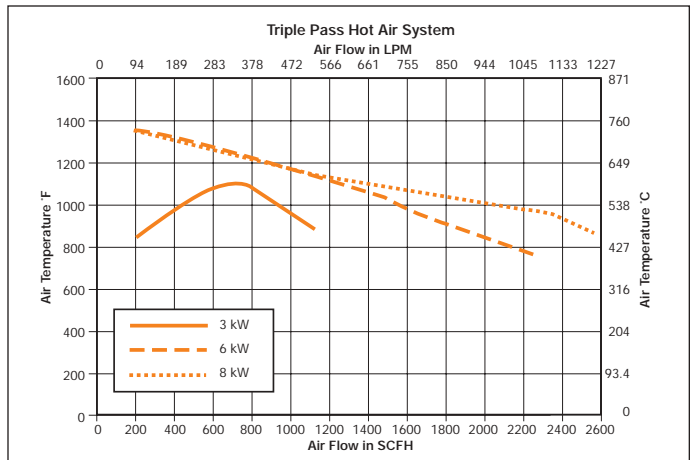
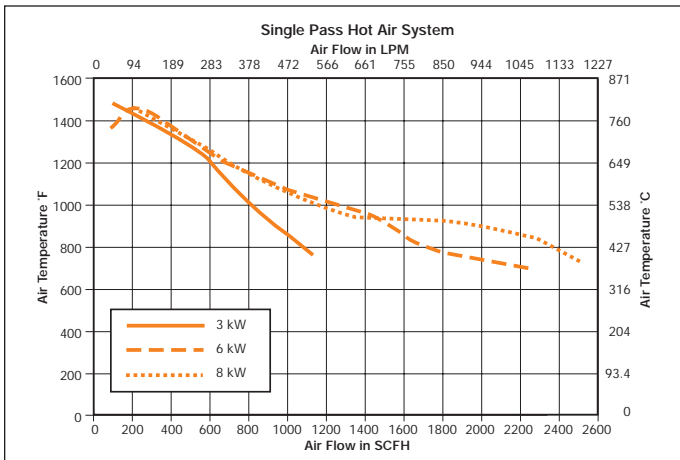

Specifications

- Single pass has built-in "K" thermocouple
- Triple pass has external mount "K" thermocouple (included with system)

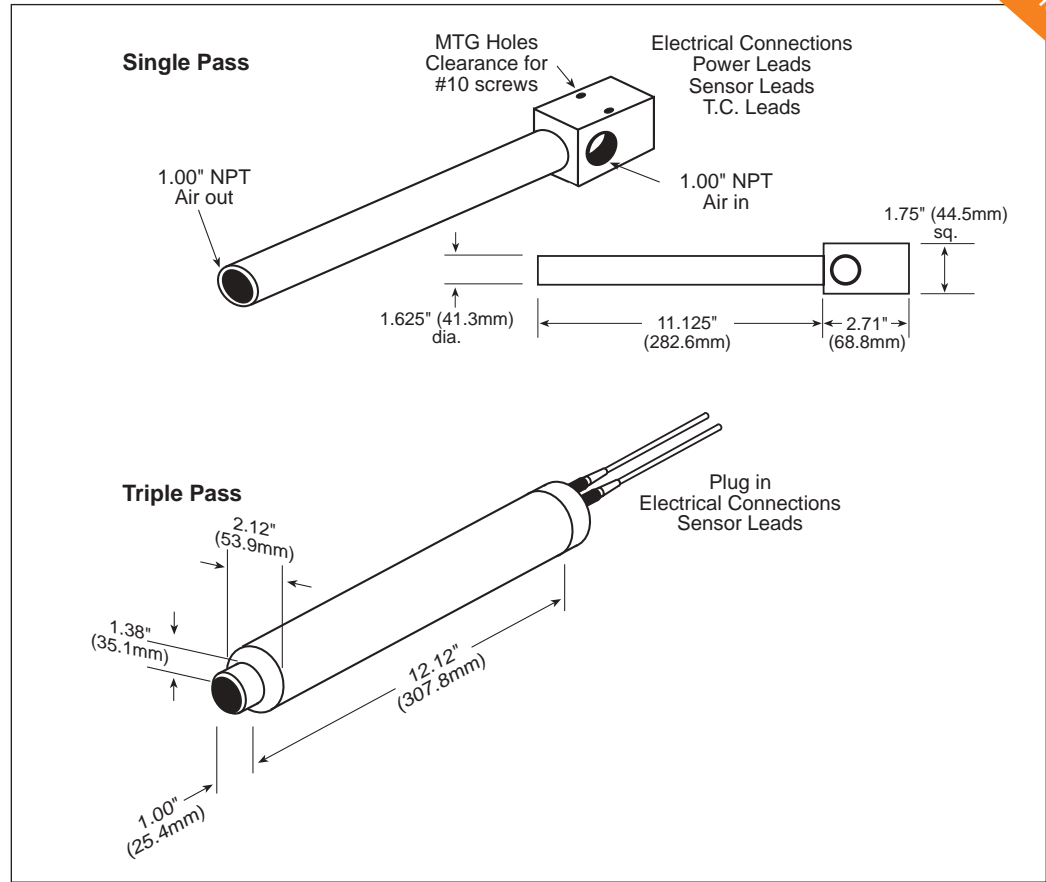

Part Number	Heater Style	Max. Watts	Max. Volts	Max. Amps	Relacement Element Part Number
068584	Single Pass	3000	240	12.5	068776
068591	Triple Pass	3000	240	12.5	068778
068586	Single Pass	6000	240	25.0	068788
068593	Triple Pass	6000	240	25.0	068819
068588	Single Pass	8000	240	33.3	068789
068595	Triple Pass	8000	240	33.3	068821

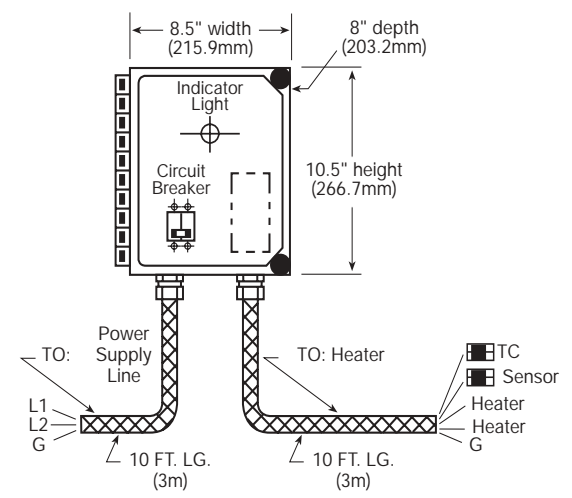

Replacement Parts Available

Part Number	Description
069964	SCR power control with overtemperature circuit (includes heat sink)
070429	Digital temperature controller, 1/16 DIN
070391	10' heater and sensor cord
039272	"K" type thermocouple probe (Triple Pass)
073248	Thermocouple adaptor port (Triple Pass)

SureHeat™ 36,000

19

Features

- Air/inert gas temperatures to 1400°F (760°C)
- Revolutionary heater burnout protection circuitry
- Plug-in replaceable elements
- Maximum air pressure 10 PSI
- Up to 36kW in a compact 16" size
- Low pressure drop across heater (suitable for use with blower)

The new OSRAM SYLVANIA SureHeat 36,000 provides the power of a high temperature (1400°F / 760°C), high volume, multi-element heater in a surprisingly compact package. The SureHeat 36,000 combines our time proven Serpentine Element design with our new integrated control technology, producing a



flexible, reliable heater, which is capable of easily and safely interfacing with just about any temperature controller, PLC, or power controller. At the heart

of this revolutionary new technology is our new sensing circuitry, which directly measures the heater's element temperature. Due to this new

design, full power can be applied to the heater without any airflow, allowing instantaneous heat response to intermittent air or product flow.

Heater Selection

To determine the proper size heater, plot a point, which defines your required air temperature and flow. The nearest curve to the right and above this point represents the proper heater selection.

All temperature measurements were created using an exposed junction, 1/16" diameter "K" thermocouple.

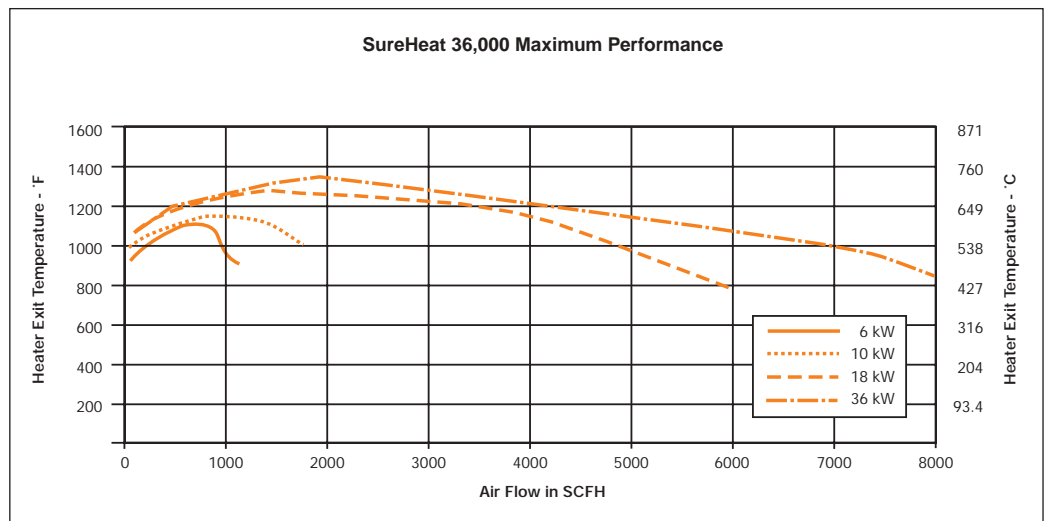

Specifications

For detailed operating instructions, visit www.sylvaniaheaters.com

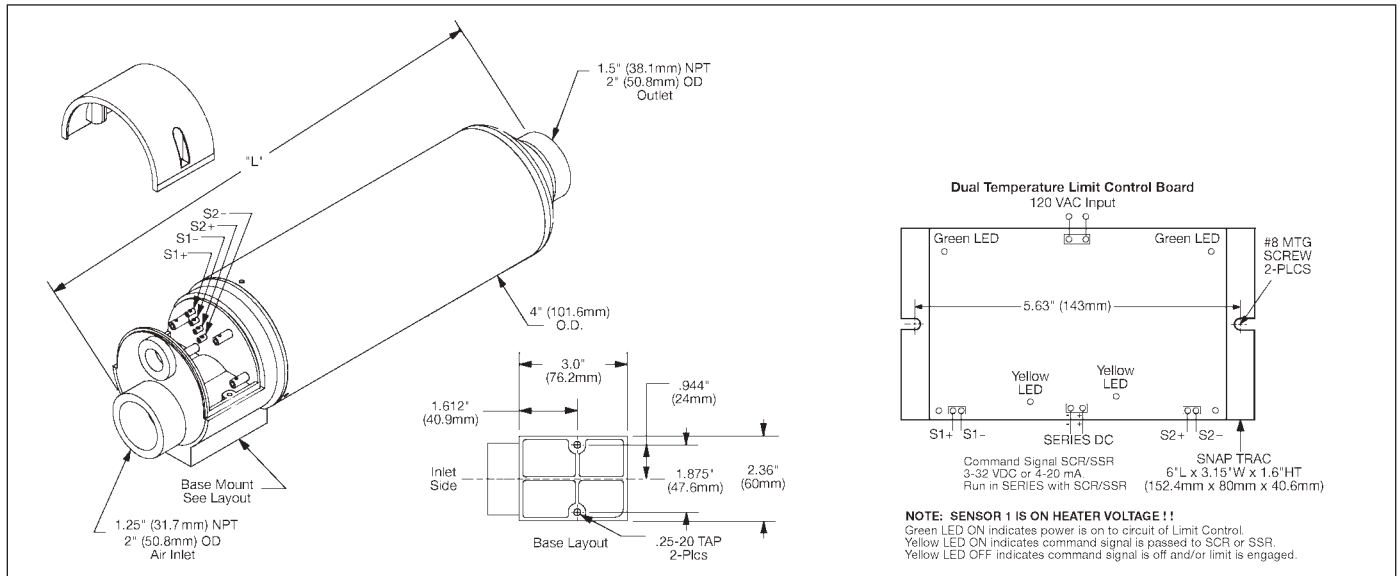

Part Number*	Maximum Watts	Maximum Volts	Phase	Maximum Amp Draw	Heater Length "L"	Replacement Element Part Number
072768	6,000	240	1	25.0	12" (31cm)	072795
072769	6,000	240	3	14.5	12" (31cm)	072796
072771	6,000	380	3	9.1	12" (31cm)	072797
072772	6,000	480	3	7.2	12" (31cm)	072798
072773	10,000	240	1	41.7	12" (31cm)	072799
072774	10,000	240	3	24.1	12" (31cm)	072801
072775	10,000	380	3	15.2	12" (31cm)	072802
072776	10,000	480	3	12.0	12" (31cm)	072803
072777	18,000	380	3	27.4	16" (41cm)	072804
072778	18,000	480	3	21.7	16" (41cm)	072805
072779	36,000	380	3	54.8	16" (41cm)	072806
072781	36,000	480	3	43.4	16" (41cm)	072807

*includes housing assembly, element, and over-temperature board.

Accessories

Part Number	Description
072808	Replacement over-temperature board
073272	Replacement 12" housing assembly (includes stainless nozzle/tube and base mount)
073273	Replacement 16" housing assembly (includes stainless nozzle/tube and base mount)
073395	Replacement rear cap
065832	Thermocouple port adaptor (does not include thermocouple.)
039272	"K" thermocouple probe
070429	Digital temperature controller 1/16 DIN

Flanged Inline System

21 Features

- Designed for high pressure, high flow applications
- Air/inert gas temperatures to 1400°F (760°C)
- Uses SureHeat overtemperature protection system
- Up to 192kW in a compact 2' (610mm) long size
- 150 PSI maximum air pressure
- 304 Stainless Steel ASME welded 300 lb. flanged housing
- Closed-loop control components are available
- Maximum inlet temperature 150°F
- Built-in "K" type thermocouple



The new OSRAM SYLVANIA Flanged Inline System provides the same heating capacity as similar circulation heaters but at only **one quarter of the size**. Temperature

sensors located within the heater itself sense element temperatures and inlet air temperature at the heater lead connection. Because of this system, full power can be

applied to the heater without airflow, allowing instantaneous heat response to intermittent air or product flow.

Heater Selection

To determine the proper size heater, plot a point, which defines your required air temperature and flow. The nearest curve to the right and above this point represents the proper heater selection.

All temperature measurements were created using an exposed junction, 1/16" diameter "K" thermocouple.

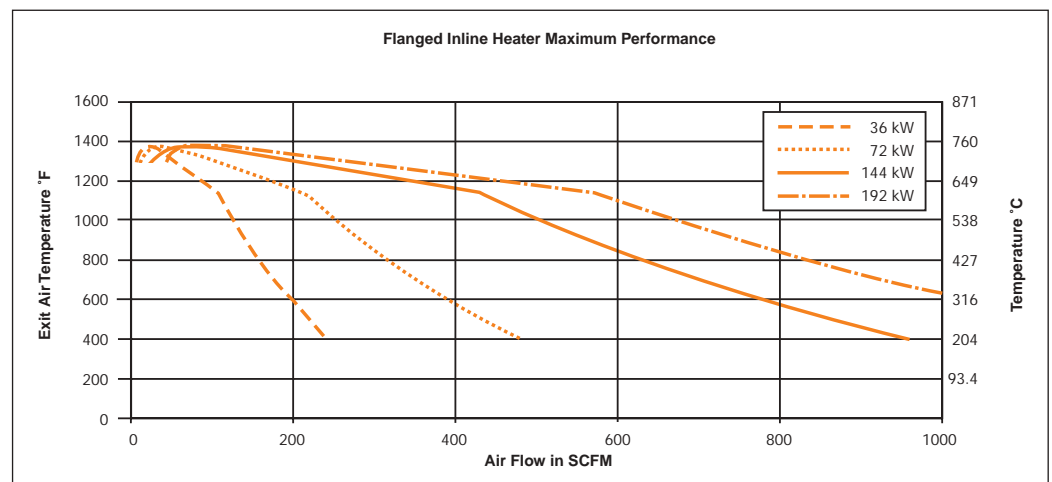

Specifications

For detailed operating instructions, visit www.sylvaniaheaters.com

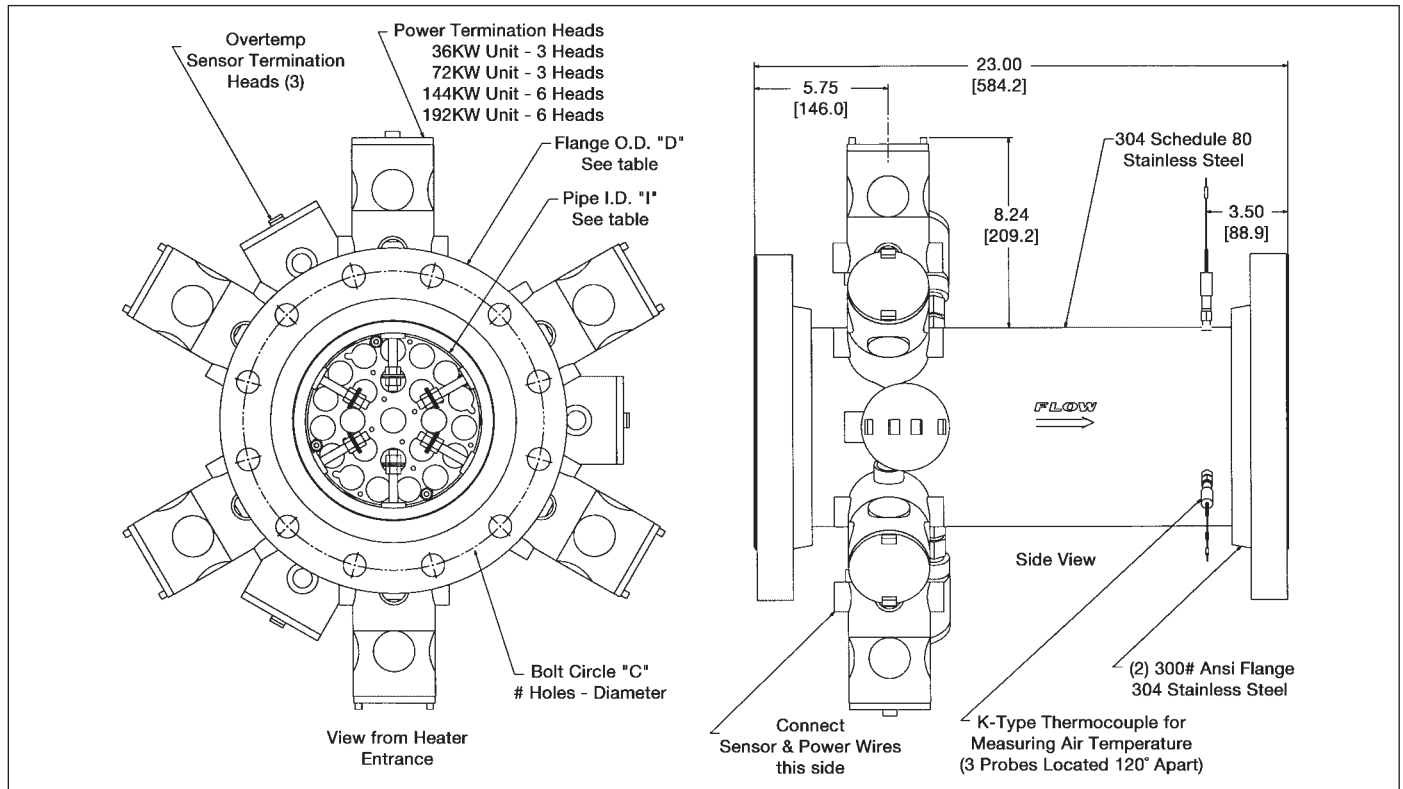

Heater Part Number*	Max. kW	Max. Volts	Max. Amps	Pipe I.D. "I"	Flange O.D. "D"	Bolt Circle "C" # Holes/Dia.	Replacement Element Part Number	SCR Power Control Part Number
073166	36.0	480 - 3Ø	45	4.0" (102mm)	10.0" (254mm)	8-.088"/7.88"	073167	072765
073377	72.0	480 - 3Ø	87	6.0" (152mm)	12.5" (318mm)	12-.088"/10.62"	073378	072764
073384	144.0	480 - 3Ø	175	8.0" (203mm)	15.0" (381mm)	12-1.00"/13.00"	073385	072763
073153	192.0	480 - 3Ø	235	8.0" (203mm)	15.0" (381mm)	12-1.00"/13.00"	073253	072762

*includes element

A complete functional system must have **heater, SCR power control, over-temperature board, and digital temperature control.**

Accessories

Part Number	Description
070429	1/16 DIN digital temperature control
073262	Over-temperature control board (required)
039272	Replacement "K" type thermocouple probe

Ceramic Infrared Heaters

23 Features

- Mid-to-far wavelength infrared heat source provides uniform heat over a large area
- Surface temperature to 750F
- Rose color glaze changes to gray to indicate operation
- Available in 122mm x 60mm, 245mm x 60mm, and 122mm x 122mm sizes.
- Available with built-in type K thermocouple.

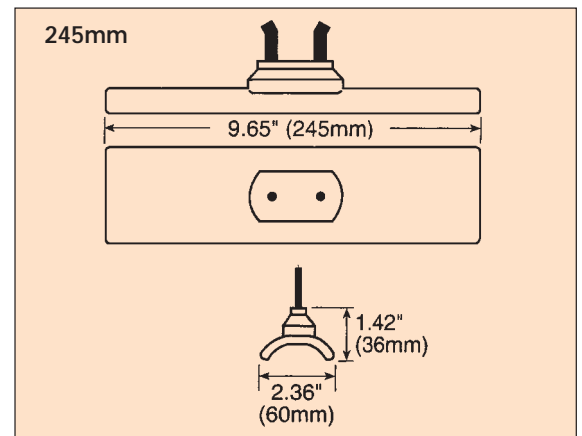
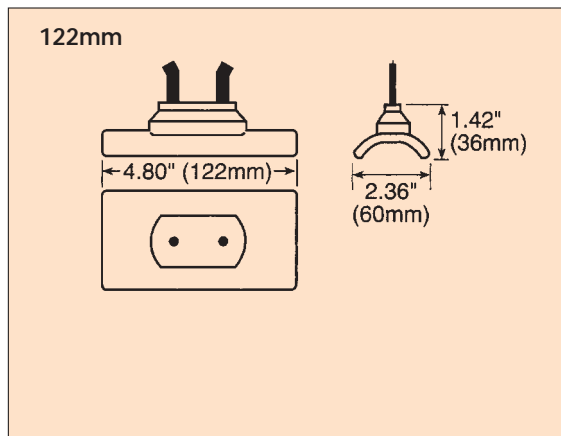

Standard leads are 4" long with pin terminals.

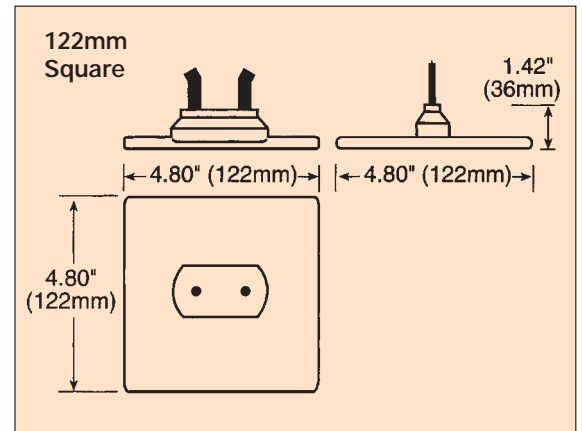

Applications

Plastics:

- Thermoforming
- Vacuum forming
- Curing extruded parts
- Drying
- Laminating

Electronics:

- Preheat PCBs
- IR reflow ovens for SMT

Paper:

- Speed drying coated paper
- Adhesive activation

Textiles:

- Drying dyed/printed fabric
- Curing latex coatings

Ceramic:

- Drying glazes/pigments

Thin Film Deposition:

- Vacuum coating substrates

Wood/Furniture:

- Heating bonded/painted/plastic coated components
- Drying same components

Food:

- Warming
- Baking

Paint:

- Drying lacquers/finishes
- Baking lacquers/finishes

Packaging:

- Heat shrink
- Forming

Printing:

- Ink drying

Element Selection

Application	RATED WATTAGE (122/245 mm)			
	125/250W	200/400W	325/650W	500/1000W
Pre-heating sheet and panels in vacuum molding machines				
Manufacture of skin packs				
Jelling PVC paste coatings on fabrics				
Heather paper pulp before pressing				
Rapid drying of lacquered paper and card				
Rapid drying of gummed and adhesive coated paper				
Activating adhesives and hot seal coatings				
Drying plastic emulsions (latex coatings)				
Drying washed, dyed, finished textile fabrics				
Fixing nylon or perlon thread				
Heating and drying cemented wood or furniture components				
Drying skins, hides and spray colored leather				
Heating and drying cemented joints of shoes				
Drying sprayed-on glazes on ceramic tiles				
Drying and baking painted sheet metal components				
Heating substrates in vacuum chambers				

Operating Specifications

25

Heater Size/heater Type	Watts	Volts	Average Surface Temp. (C°)	Peak Wavelength (µm)	Part Number Without TC	Part Number With "K" TC
122mm x 60mm	125	220/230	420	4.3	069937*	069939*
	200	220/230	510	3.7	069938	069941
	325	120	630	3.2	066622*	066623*
	325	220/230	630	3.2	066305	066381
	325	480	630	3.2	066624*	066625*
	500	120	750	2.9	066626*	066627*
	500	220/230	750	2.9	066306	066382
	500	480	750	2.9	066628*	066629*
245mm x 60mm	150	220/230	310	4.9	069942*	069945*
	250	220/230	420	4.3	069943*	069946*
	400	220/230	510	3.7	069944*	069947*
	650	120	630	3.2	066631*	066632*
	650	220/230	630	3.2	066301	066386
	650	480	630	3.2	066633*	066634*
	1000	120	750	2.9	066635*	066636*
	1000	220/230	750	2.9	066302	066387
	1000	480	750	2.9	066637	066638
122mm Square Flat*	400	220/230	510	3.7	069948*	069949*
	650	120	630	3.2	066639*	066641*
	650	220/230	630	3.2	066389*	066392*
	650	480	630	3.2	066642*	066643*
	1000	120	750	2.9	066644*	066645*
	1000	220/230	750	2.9	066646*	066647*
	1000	480	750	2.9	066648*	066649*

*Minimum order quantity on these parts is 50 pieces.

Surface Temperature

	122 mm WATTAGE					245 mm WATTAGE			
	125	200	325	500	150	250	400	650	1000
Average Surface Temperature, °C	420	510	630	750	310	420	510	630	750
Maximum Allowable Surface Temperature, °C	550	600	700	800	450	550	600	700	800

Note: Actual surface temperature will vary depending on ambient air temperature and reflective surfaces near the heater.

Technical Data

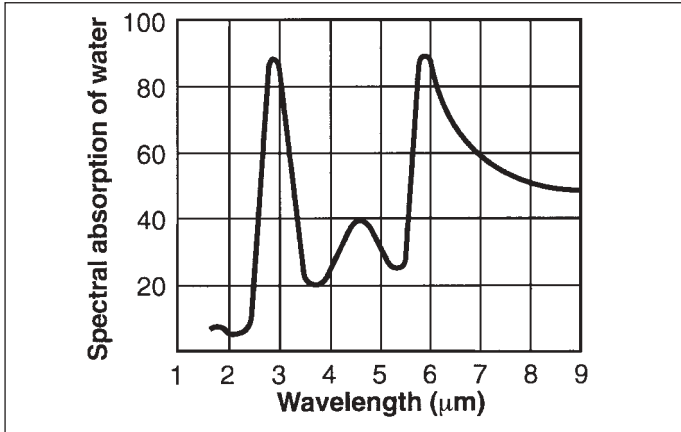

This diagram shows that water absorbs long wave infrared very well. Absorption maxima are approx. 3 and 6 μm.

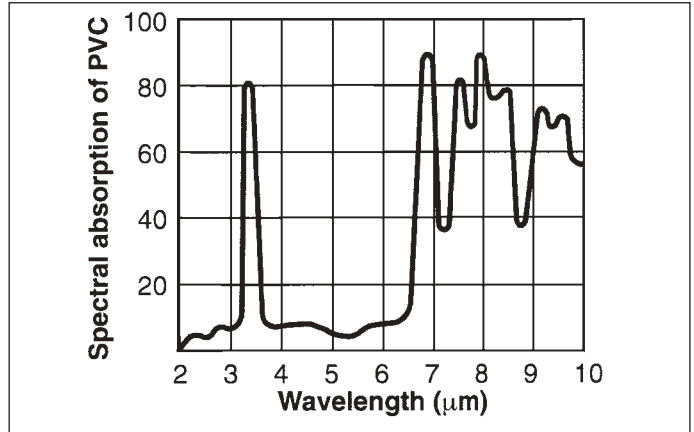

This is the spectral absorption of PVC. The main absorption range lies between 7 and 10 μm. The curves for other plastics exhibit a similar character.

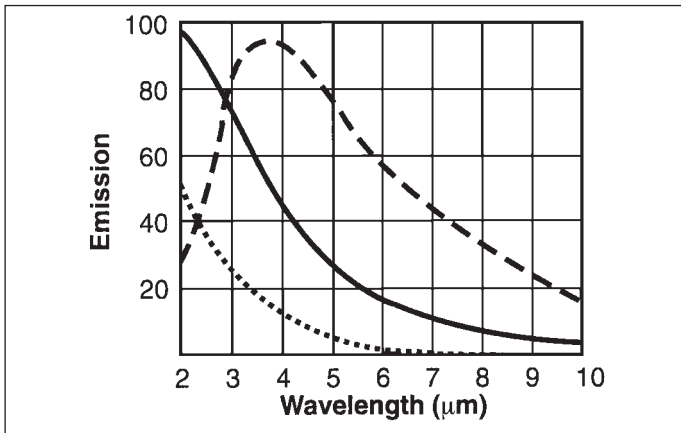

Emission spectrum of black body radiators. Dotted Line: 2100°C (as for visible radiators); Solid Line: 1100°C (as for quartz radiators); Dashed Line: 510°C for ceramic radiators, best range 3 to 10 μm.

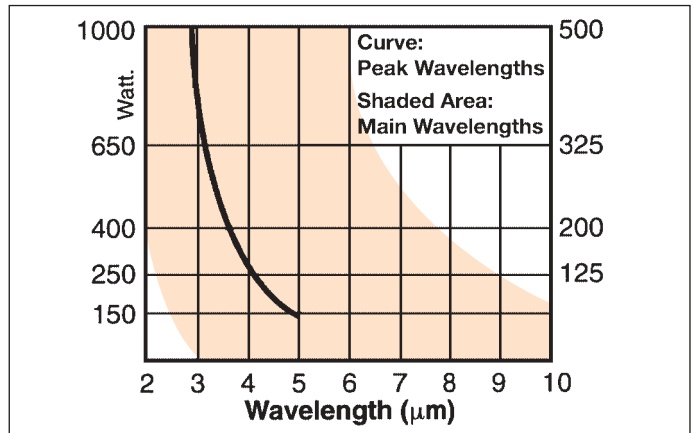

This graph enables peak wavelength and main wavelength to be determined for each radiator's power rating.

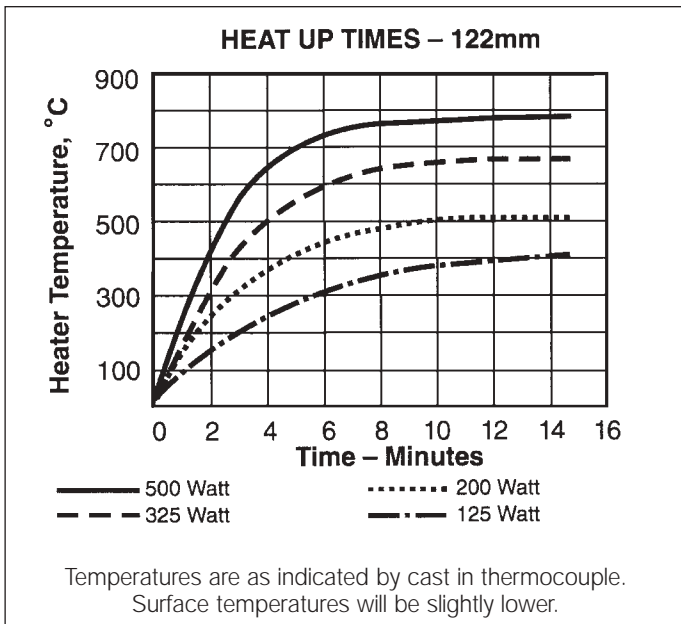

Temperatures are as indicated by cast in thermocouple. Surface temperatures will be slightly lower.

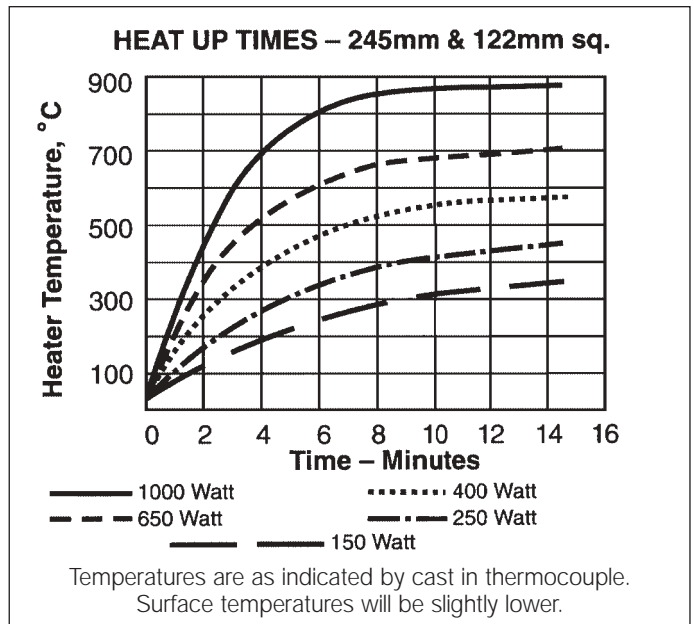

Temperatures are as indicated by cast in thermocouple. Surface temperatures will be slightly lower.

Assemblies & Accessories

27

Accessory	Part Number	Part Number	A	B
Reflector for 122mm Heaters	030121	030143	10.2"	9.5"
Reflector for 245mm Heaters	030122	030144	20.2"	19.5"
10" Housing	030143	030145	30.2"	29.5"
20" Housing	030144	030146	40.2"	39.5"
30" Housing	030145			
40" Housing	030146			
Terminal Block - 2 Pole	037443			
1-Piece Clip*	047168			
2-Piece Clip	069307			

* Included with heater

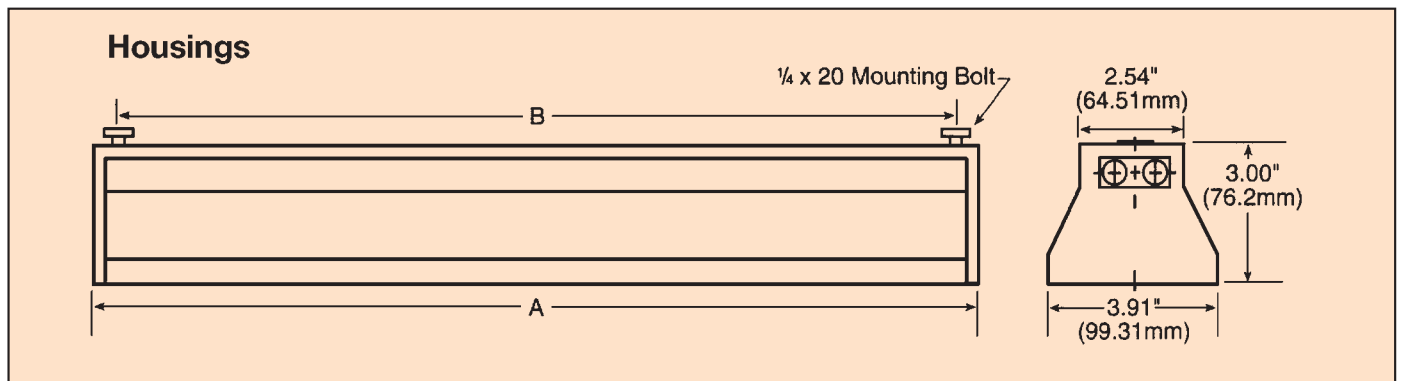

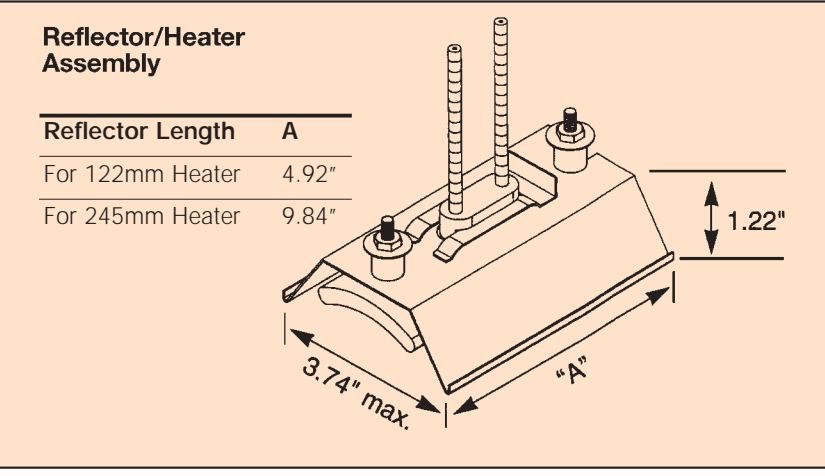
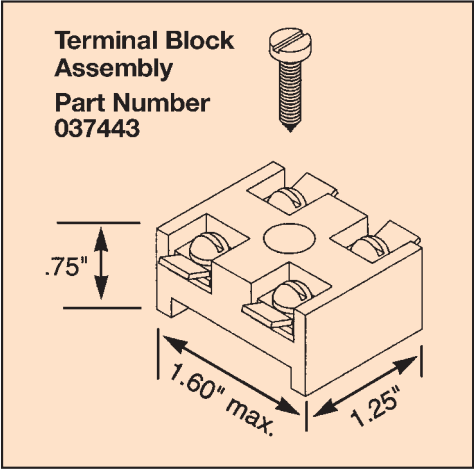
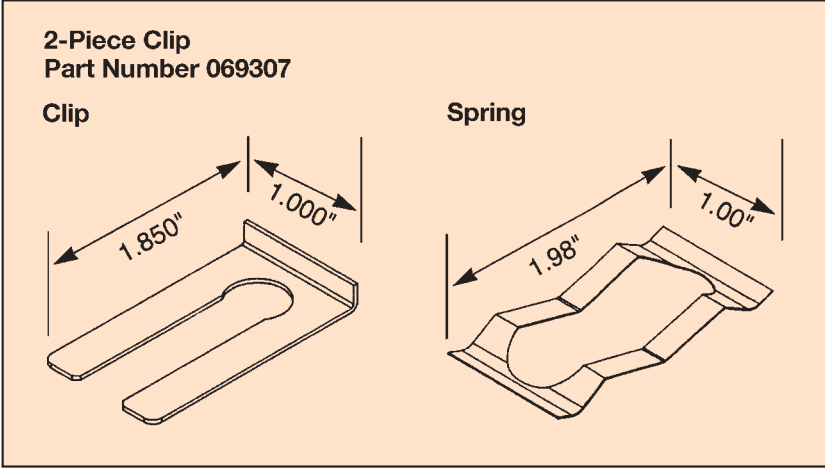
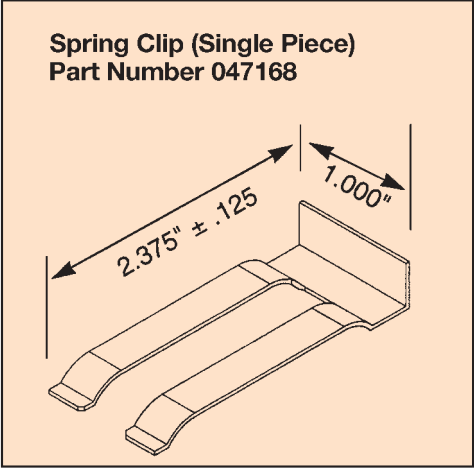

Reference Data

29 A. Air Heater Energy Requirement

$$\text{kW} = \text{SCFM} \times (\text{Texit} - \text{Tinlet}) / 2500$$

B. Temperature Conversions

$$^{\circ}\text{F} = 9/5 (^{\circ}\text{C}) + 32$$

$$^{\circ}\text{C} = 5/9 (^{\circ}\text{F} - 32)$$

C. Air Flow Conversions

$$\text{SCFM} = \text{SCFH} / 60 = \text{SLPM} / 28.3$$

$$\text{SLPM} = \text{SCFH} / 2.12$$

$$\text{SCMH} = \text{SCFH} / 35.3$$

$$\text{SCFM} = (\text{Pounds of Air Per Minute}) / (.080 \text{ lbs/ft}^3)$$

SCFM = Standard Cubic Feet per Minute

SCFH = Standard Cubic Feet per Hour

SLPM = Standard Liters per Minute

SCMH = Standard Cubic Meters per Hour

D. Single Phase Wiring

$$V = I \times R \quad (\text{Volts} = \text{Amps} \times \text{Ohms})$$

$$I = W / V \quad (\text{Amps} = \text{Watts} / \text{Volts})$$

$$W = V^2 / R \quad (\text{Watts} = (\text{Volts} \times \text{Volts}) / \text{Ohms})$$

E. Three Phase Wiring

Delta Configuration

$$R = R_1 = R_2 = R_3$$

$$W_{\text{delta}} = 3(V_L^2) / R$$

$$W_{\text{delta}} = 1.73 \times V_L \times I_L$$

$$I_P = I_L / 1.73$$

$$V_P = V_L$$

Wye Configuration

$$R = R_1 = R_2 = R_3$$

$$W_{\text{wye}} = (V_L^2) / R = 3(V_P^2) / R$$

$$W_{\text{wye}} = 1.73 \times V_L \times I_P$$

$$I_P = I_L$$

$$V_P = V_L / 1.73$$

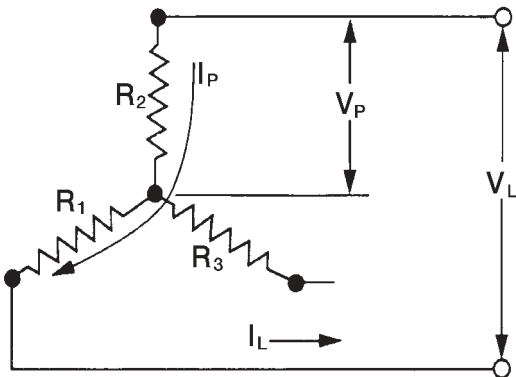

Wye Configuration

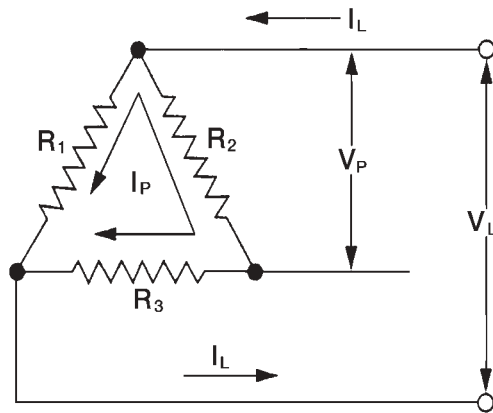

Delta Configuration

WARNING: OSRAM SYLVANIA Air/Inert Gas Heaters should be used to heat air or an inert gas only. Use with explosive gases or in an explosive ambient can result in an explosive event, possibly leading to a serious accident or injury.

The information and recommendations contained in this publication are based upon data collected by OSRAM SYLVANIA and believed to be correct. However, no guarantee or warranty of any kind, expressed or implied, is made with respect to the information contained herein, and OSRAM SYLVANIA assumes no responsibility for the results of the use of products and processes described herein. No statements or recommendations made herein are to be construed as inducements to infringe any relevant patent, now or hereafter in existence.

OSRAM SYLVANIA
Portsmouth Avenue
Exeter, NH 03833 USA
Tel. 800-258-8290
In NH 603-772-4331
Fax 603-778-4503
www.sylvaniaheaters.com

