

# OPERATING INSTRUCTIONS

8/12/00

OSRAM  
**SYLVANIA**  
Process Heat

## HOT AIR SYSTEM

SINGLE PASS 068584, 068586, 068588

TRIPLE PASS 068591, 068583, 068595

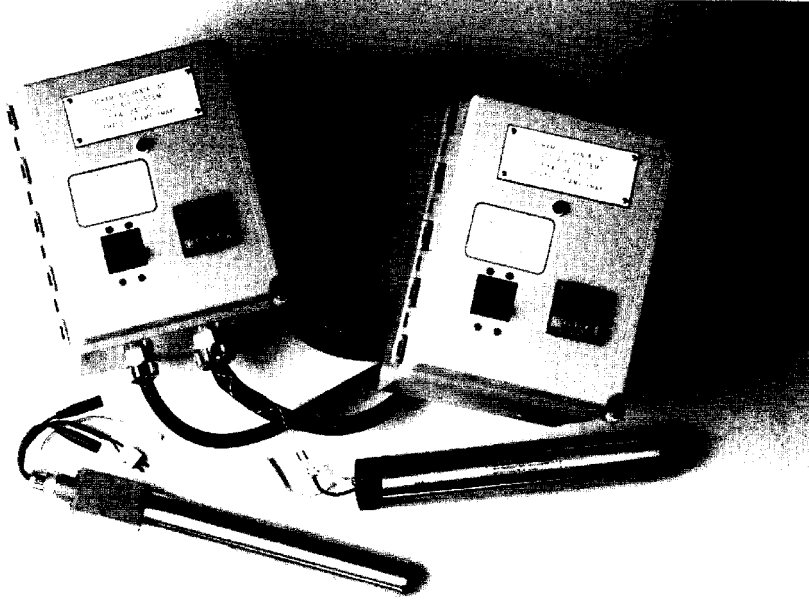

⇒ FOR SAFETY AND LONG HEATER LIFE, CAREFULLY READ THIS MANUAL BEFORE USE.

### Description

- Compact, safe and efficient heater for heating air and inert gases to 1400°F (760°C). The Hot Air System is available with single or triple-pass element styles, for high and low-pressure gas applications, respectively. The Hot Air System comes with a control box containing a temperature controller, power controller, and over-temperature protection circuitry. The special over-temperature circuitry prevents heater burnout if airflow is interrupted, or the temperature is accidentally set too high. If operated correctly, the Hot Air System will operate continuously for 5000 hours or longer.

### Specifications

MAXIMUM INLET AIR TEMPERATURE	100°F (38°C)
MAXIMUM EXIT AIR TEMPERATURE	1400°F (760°C)
MAXIMUM PRESSURE (SINGLE PASS)	100 PSI (Mechanical limit)*
MAXIMUM PRESSURE (TRIPLE PASS)	25 PSI

\*NOTE THERE WILL BE SOME AIR LEAKAGE THROUGH THE LEAD WIRES AT HIGH PRESSURES (>50 PSI approx.)

MODEL NUMBER	ELEMENT STYLE	MAXIMUM WATTAGE	MAXIMUM VOLTAGE	AMP RATING	REPLACEMENT ELEMENT NUMBER
068584	SINGLE PASS	3000/750	240/120	12.5/6.3	068776
068586	SINGLE PASS	6000/1500	240/120	25.0/12.5	068788
068588	SINGLE PASS	8000/2000	240/120	33.3/16.7	068789
068591	TRIPLE PASS	3000/750	240/120	12.5/6.3	068777
068593	TRIPLE PASS	6000/1500	240/120	25.0/12.5	068817
068595	TRIPLE PASS	8000/2000	240/120	33.3/16.7	068818

## Safety

- ❑ **SHOCK HAZARD** Only qualified individuals should install this heater and related controls. Follow all applicable electrical codes and use proper wiring.
- ❑ **BURN/FIRE/EXPLOSION HAZARD** Do not use with or near explosive or reactive gases. Avoid contact with the side, or exposure to the exit-end, during or soon after operation. **DO NOT USE NEAR VOLATILE OR COMBUSTIBLE MATERIALS.**

## Precautions

- ❑ Use filtered air. Avoid dirt, grease, oil, or oil vapors, corrosive or reactive gases which will damage heater.
- ❑ Regenerative blowers may generate high inlet air temperatures which will activate the inlet sensor. Check blower temperature rise data before selecting a blower.
- ❑ Control box must be in a clean, dry environment between 32°F and 130°F. The cooling fins on the back of the control box must be vertical and have free air circulation.
- ❑ Do not subject the heater to excessive vibration or mechanical shock.
- ❑ Inlet air must be 0 to 100°F for proper operation.
- ❑ Disconnect electrical power to the system before replacing elements.
- ❑ Allow air to cool the heater so all parts are cool to the touch prior to replacing heater elements.

## Installation

- Securely mount the heater and control box. (see Precautions)
- Connect the power cord to a properly fused supply. Follow all applicable electrical codes and use proper wiring.
- Verify the heater to control box cord is securely plugged in. Connectors are color coded and polarized. All connections must be secure for the heater to run.
- Connect the filtered air source to the heater.
- If a thermocouple is used, ensure that it is located within one inch from the heater exit.

## Start-up

- Turn on air supply and adjust to desired flow/pressure.
- Turn on power to the system (circuit breaker on box).
- Set temperature controller to the desired exit air temperature.
- Exit air temperature (process value – PV) will increase to the set value (SV) and stabilize.
- When turning the system off, it is recommended that power be turned off before the air to allow the heater to cool and reduce the burn hazard.
- Air flow may be changed or turned off at any time without any damage to the heater. The air temperature may be set at any level, but depending on the flow rate, the heater may not reach that temperature. Check Performance Curves to determine maximum air temperature at different flow rates.

The over-temperature circuit works as follows: An optical sensor (photodarlington cell) and temperature sensor (thermistor) are connected in parallel at the entrance end of the heater. The optical sensor senses element temperature, while the thermistor senses inlet air temperature. If the element temperature is accidentally turned too high, the optical sensor decreases in resistance and activates the over-temperature control circuit cutting power to the heater. If the airflow is turned off, ambient heat migrates to the entrance end and, if greater than 100°F, activates the thermistor, which activates the control circuit and cuts heater power. If the inlet temperature is approx. 220°F or above, the system will turn heater power off completely.

## **Element Replacement**

### **Single Pass**

The single pass element and housing is integrated into a complete unit. The element portion cannot be removed from the high-pressure housing.

1. Turn system power off.
2. Allow heater to cool to the touch before changing element.
3. Disconnect air supply from heater.
4. Unplug the sensor, thermocouple, and power plugs from the rear of the heater.
5. Plug sensor, thermocouple, and power plugs from control cord into new heater.
6. Reconnect air supply.

### **Triple Pass**

The triple pass heater contains a replaceable cartridge.

1. Turn system power off.
2. Allow heater to cool to the touch before changing element
3. Unplug the sensor, thermocouple, and power plugs from the rear of the heater.
4. Remove the two screws at the entrance end (black nylon adapter) of the heater exchanger, grab the black adapter, and pull out heater cartridge.
5. Insert new cartridge and replace the two screws.
6. Plug in sensor, thermocouple, and power plugs to rear of heater.
7. Reconnect air supply.

If the element has failed prematurely, consult the factory. If returning the unit, the entire system with control box must be returned, otherwise the system cannot be evaluated.

## Performance Curves

The attached performance curves show maximum exit air temperatures at different air flows.

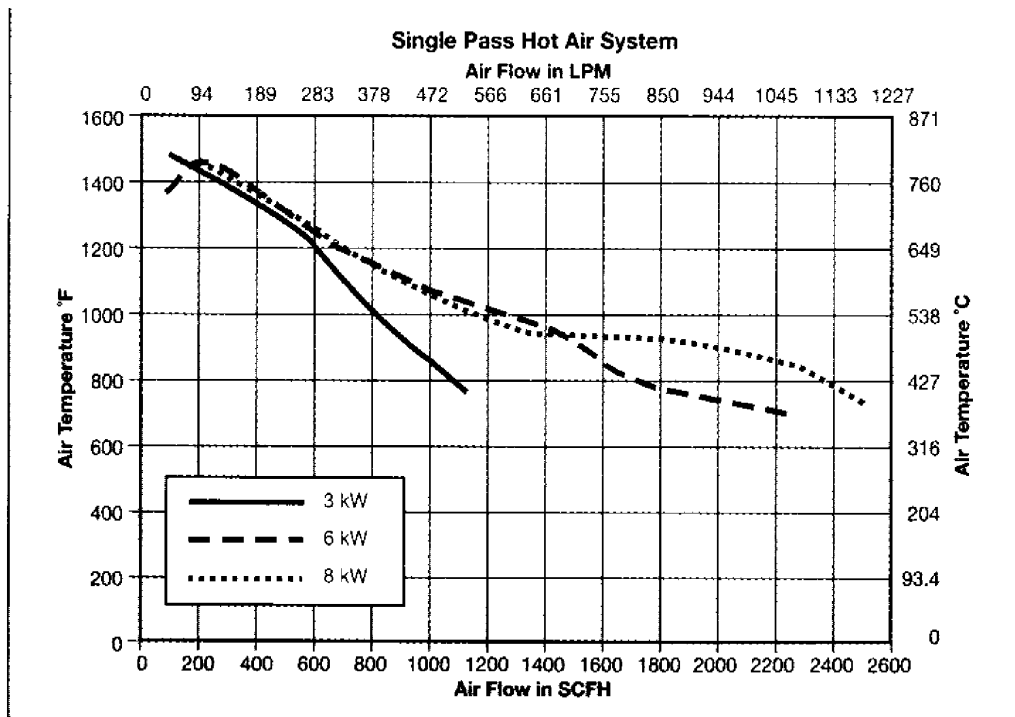
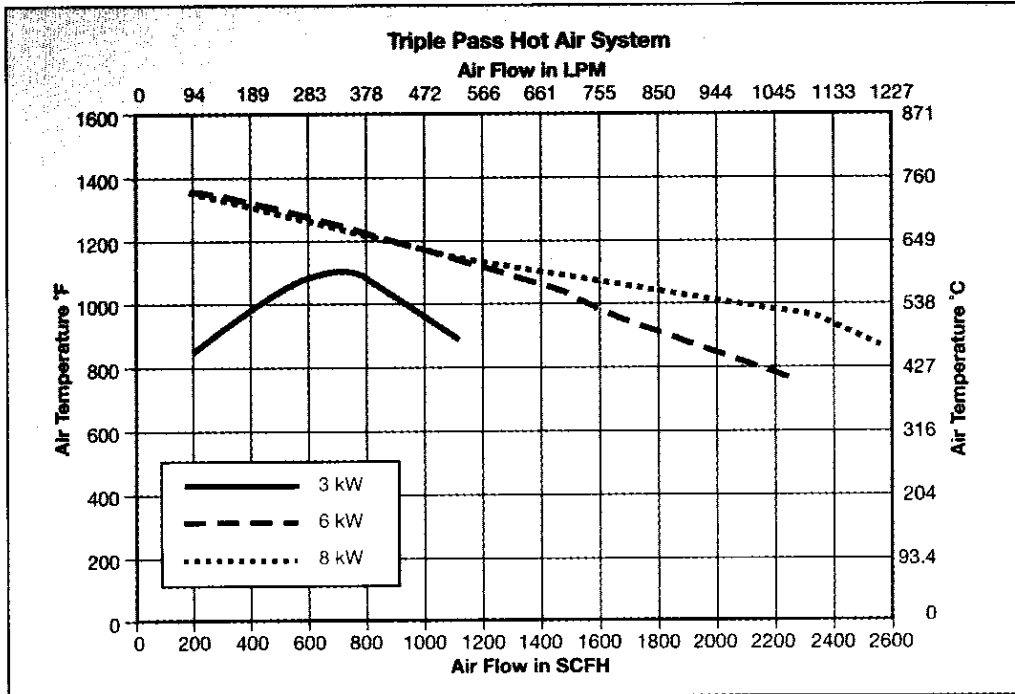

**SINGLE PASS**

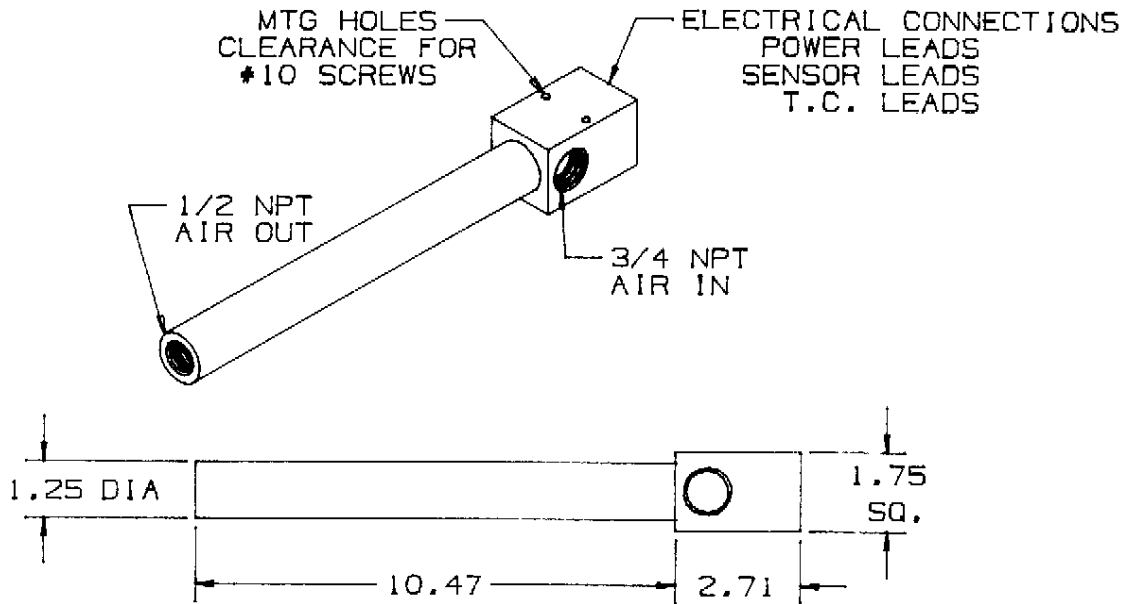

**TRIPLE PASS**

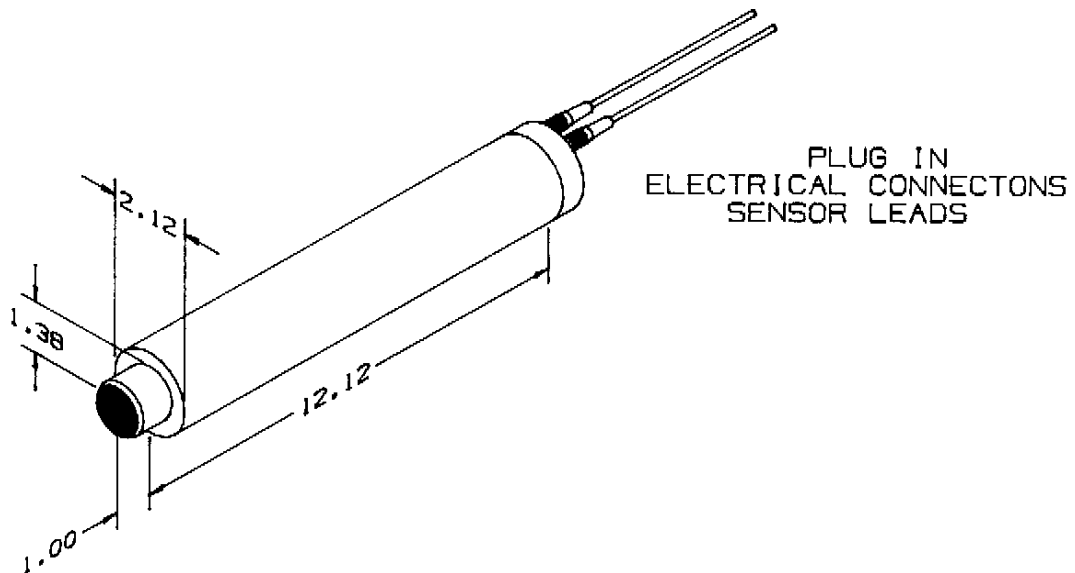

CONTROL BOX

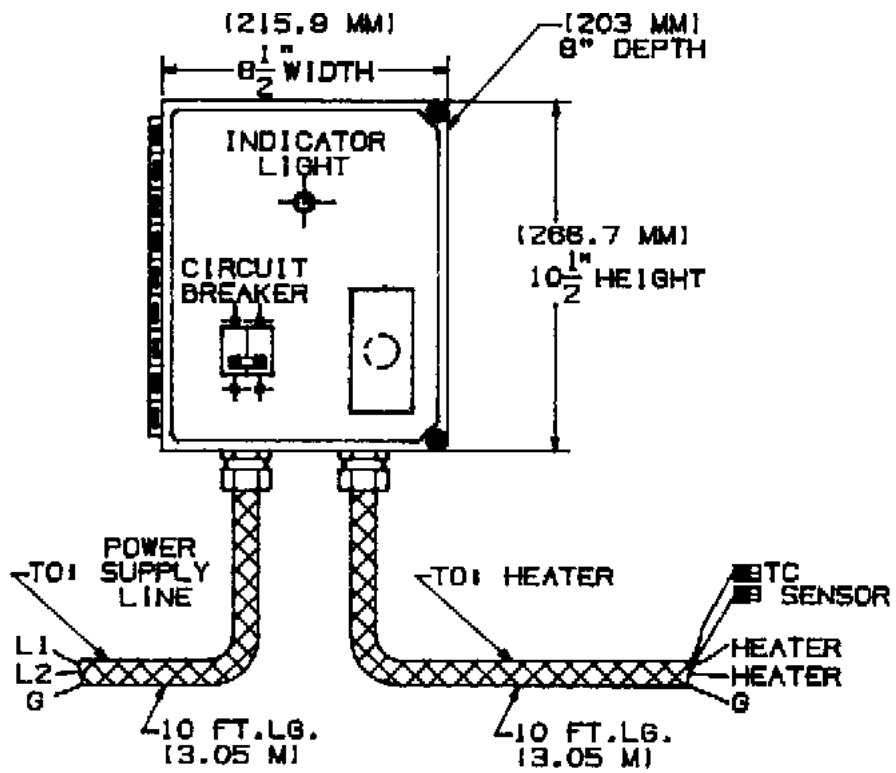

### REPLACEMENT 4-20mA POWER CONTROL (P/N 069964)

**INPUT** IS THE 4-20mA DC CONTROL SIGNAL FROM TEMPERATURE CONTROLLER.

**SENSOR** IS THE SIGNAL FROM THE OVERTEMP SENSORS LOCATED IN THE REAR OF THE HEATER (WHITE PLUG). RED WIRE = POSITIVE BLACK WIRE = NEGATIVE

DOUBLE CHECK WIRING! POLARITY IS CRITICAL FOR INPUT AND SENSOR WIRING.

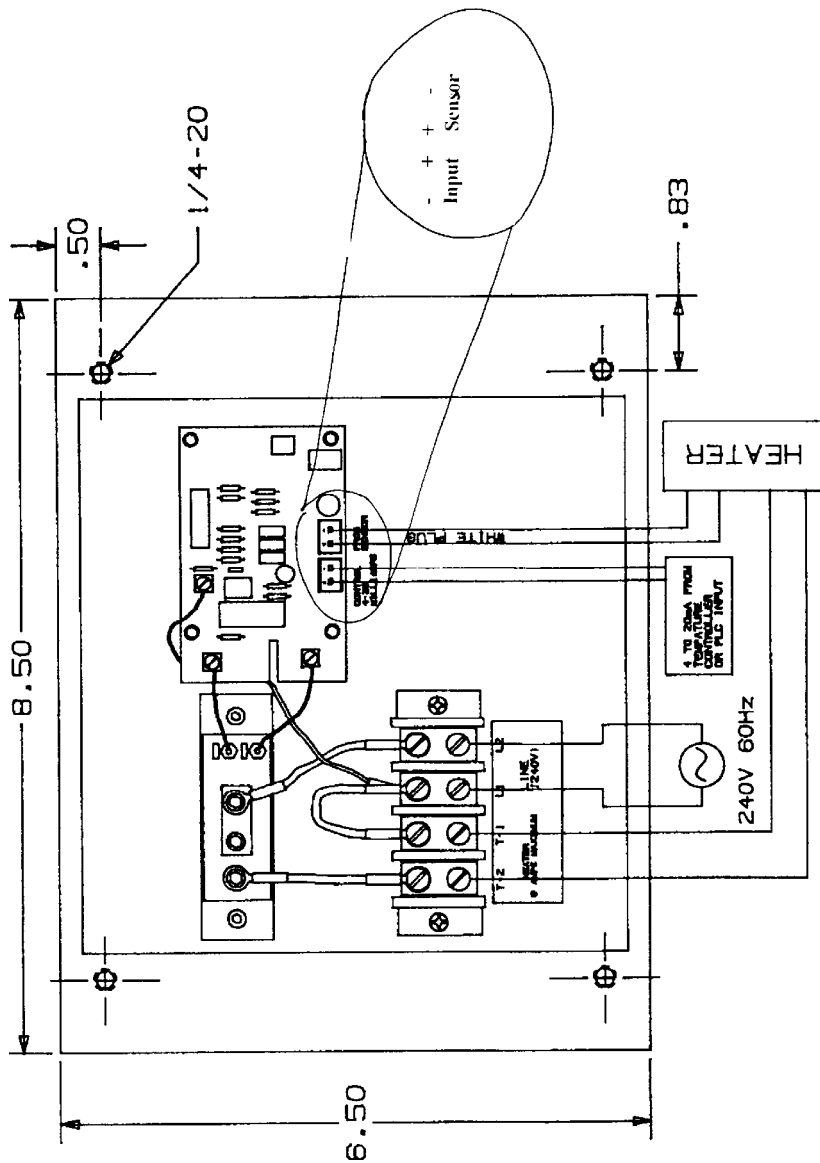

## **Warranty**

OSRAM SYLVANIA warrants that all products to be delivered hereunder will be free from defects in material and workmanship at the time of delivery. OSRAM SYLVANIA's obligation under this warranty shall be limited to (at its option) repairing, replacing, or granting a credit at the prices invoiced at the time of shipment for any of said products. This warranty shall not apply to any such products which shall have been repaired or altered, except by OSRAM SYLVANIA, or which shall have been subjected. OSRAM SYLVANIA shall be liable under this warranty only if (A) OSRAM SYLVANIA receives notice of the alleged defect within sixty (60) days after the date of shipment; (B) the adjustment procedure hereinafter provided is followed, and (C) such products are, to OSRAM SYLVANIA's satisfaction, determined to be defective.

THE WARRANTY SET FORTH IN THE PRECEDING PARAGRAPH IS EXCLUSIVE AND IN LIEU OF ALL OTHER WARRANTIES, EXPRESS OR IMPLIED, INCLUDING, WITHOUT LIMITATION, ANY IMPLIED WARRANTY OF FITNESS FOR A PARTICULAR PURPOSE OR OF MERCHANTABILITY.

The information contained in this manual is based on data considered to be true and accurate. Reasonable precautions for accuracy has been taken in the preparation of this manual, however OSRAM SYLVANIA assumes no responsibility for any omissions or errors, nor assumes any liability for damages that may result from the use of the product in accordance with the information contained in this manual.

Please direct all warranty/repair requests or inquiries to the place of purchase, and provide the following information, in writing:

- (A) Order number under which products were shipped
- (B) Model/Serial Number of product
- (C) Reason for rejection

**PRODUCTS CAN NOT BE RETURNED TO OSRAM SYLVANIA WITHOUT AUTHORIZATION.**

Replacement, repair, or credit for products found to be defective will be made by the place of purchase. All products found to be not defective will be returned to the Buyer; transportation charges collect or stored at Buyers expense.

OSRAM SYLVANIA P/N 070429 - 1/16 DIN TEMP CONTROLLER

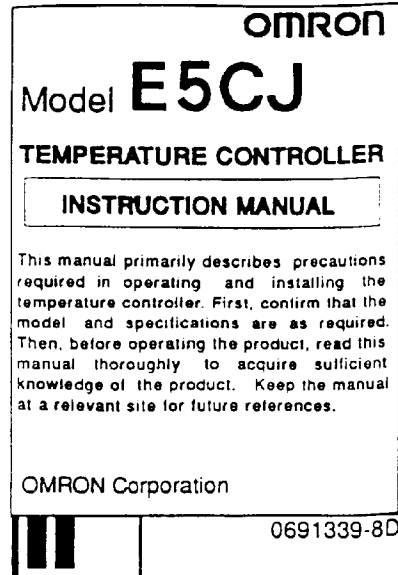

■ NAMES OF RESPECTIVE PARTS

- PV** PV display  
Displays the process value and various characters (Refer to ■ OPERATION).
- SV** SV display  
Displays various set values.
- OUT** Output indicator  
Turns on while the control output is being issued except for current output type.
- Level key**  
Shifts the display level when pressed for more than 1 s.

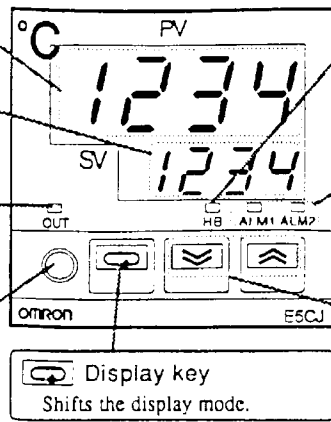

HB, ALM1, and ALM2 indicators are not provided for some models.

**HB** Heater Burnout alarm indicator  
Turns on while HB alarm is being output. To reset it, turn power off or set alarm value to 0.0 A.

**ALM1 · ALM2** Alarm 1/2 indicator  
Turns on while Alarm 1/2 is being output.

**Down key, Up key**  
Increments and decrements the set values. When the key is pressed down for 1 s or more, the numeral changes quickly. The set value becomes effective 2 s after releasing Up / Down keys or by pressing Display or Level key.

**Note:**  
Always turn on the controller and the load simultaneously. Never turn on the load when the controller is already turned on. Doing so will disable proper self-tuning and optimum control.  
For example, when setting the parameters to the controller with the load turned off, turn off the controller once after completing the setting and then turn it on again simultaneously with the load.

■ INSTALLATION

• External Dimensions

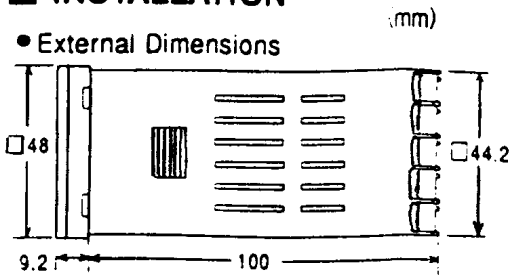

Terminal screws: M3.5 × 8

Notes:

- Insert the controller into the mounting hole, attach the provided adaptor to the controller from the back to minimize space between the panel, and fix the adaptor with screws.
- The controller should be used within -10 to 55 °C temperature and 35 to 85 % humidity.
- Take care never to let any foreign substance penetrate inside through ventilation holes provided on the case during installation.

• Panel cutout

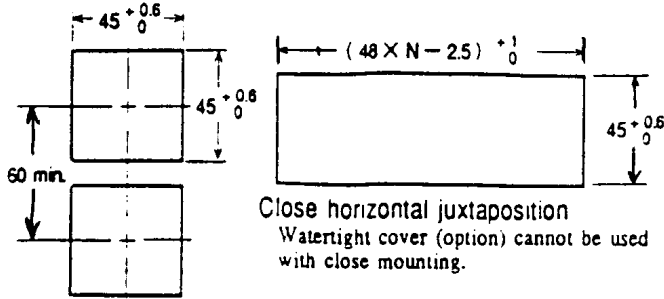

■ CONNECTIONS

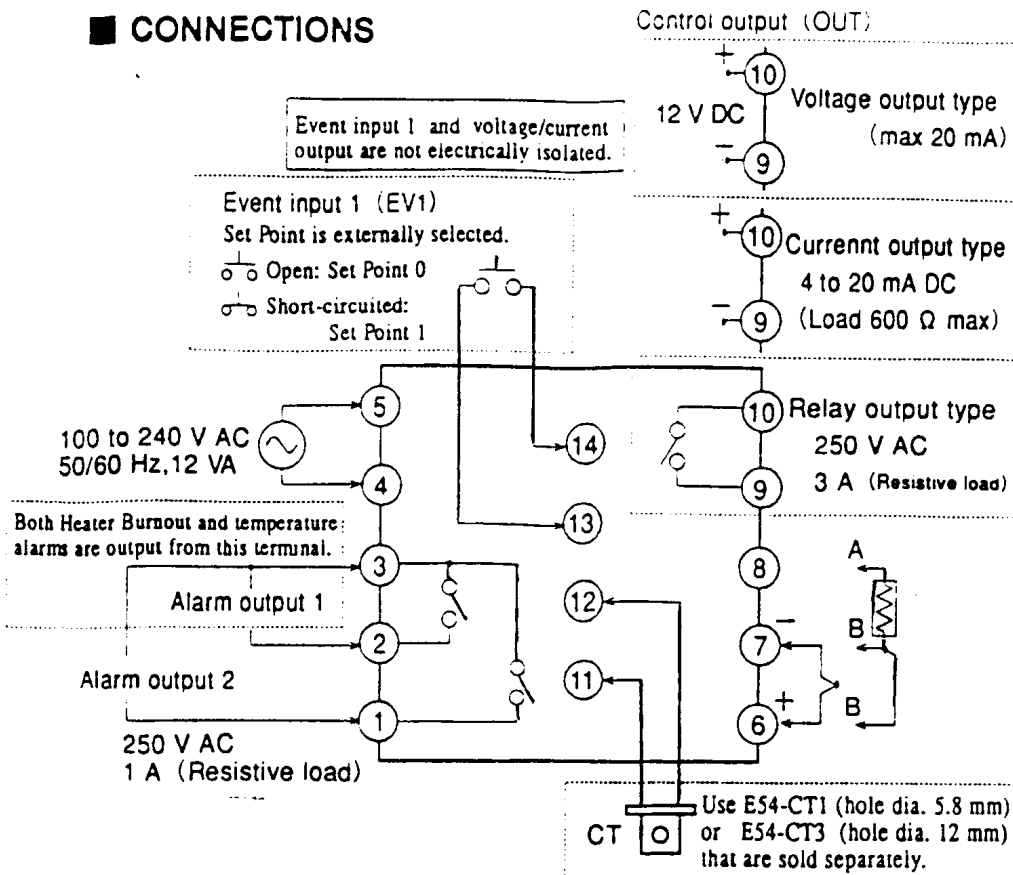

The  below means that the set values can be changed by Up / Down key while the key protection is disabled. (Refer to ■ SWITCH SETTINGS.)

■ **OPERATION** Factory settings are shown below.

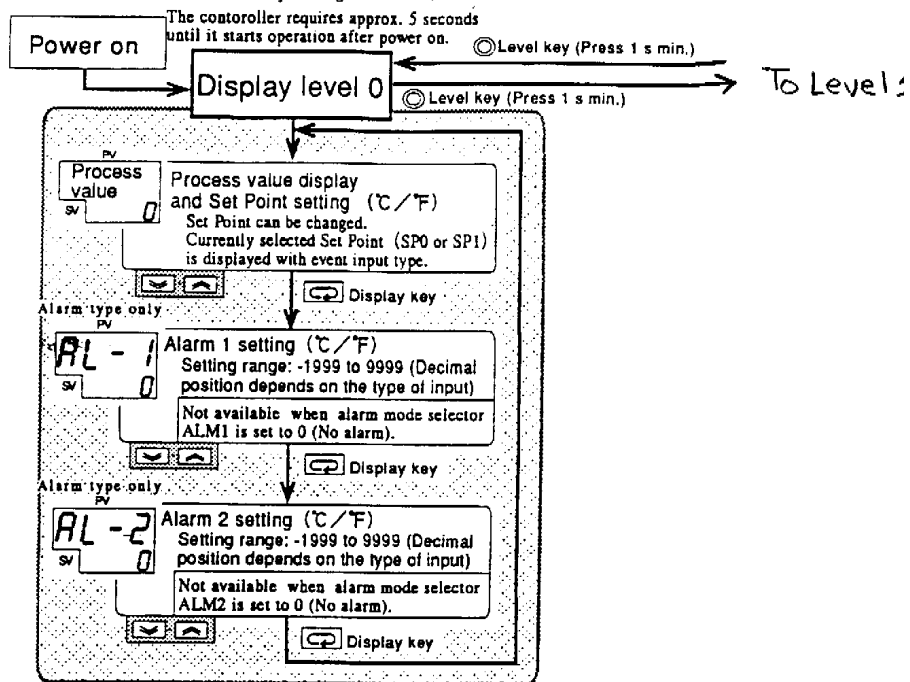

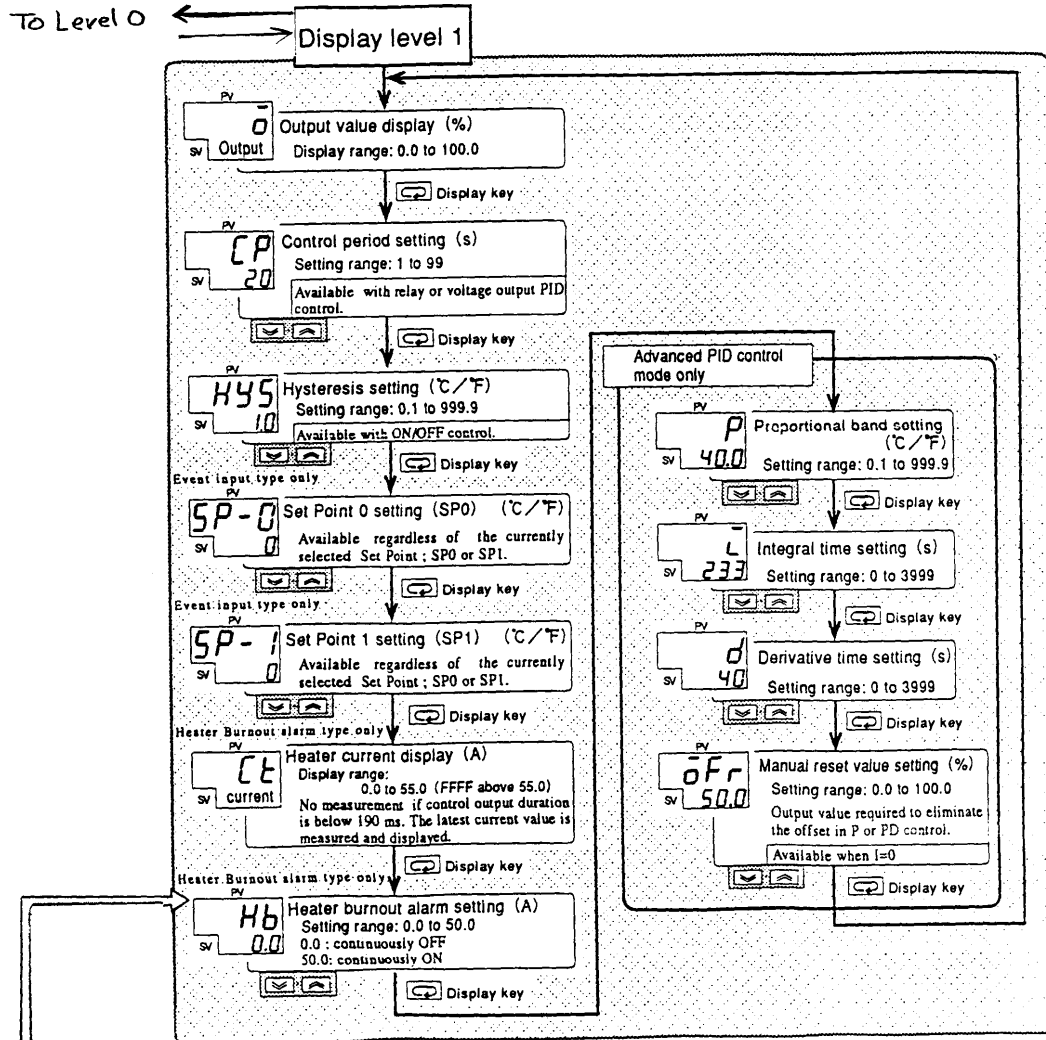

**Heater Burnout alarm setting**  
Enter Heater current display to confirm normal and Heater Burnout currents. Set intermediate value.  
Set value =  $\frac{\text{Normal current} + \text{Heater Burnout current}}{2}$   
When normal and Heater Burnout current difference is small, Heater Burnout alarm detection may become unstable. The minimum current difference are:  
1.0 A or more with heaters below 10.0 A  
2.5 A or more with heaters of 10.0 A or above.

■ OTHER FUNCTIONS

Alarm hysteresis, Set Point limit, Automatic return of display mode, and Input shift are provided in other levels. For details, ask your OMRON dealer for E5□J OPERATION MANUAL.

**■ TROUBLE SHOOTING**

PV Display	Error	Output status		Cause
		Control output	Alarm output	
SErr	Abnormal input	OFF (2mA max.)	Operates as above the upper limit.	①Input is outside the control range ( $\pm 10\%$ of the setting range) ※ ②Input type setting is incorrect. ③Input wiring is incorrect, disconnected, or short-circuited.
E111	Abnormal memory	OFF (2mA max.)	OFF	Turn power off and then on again. If the display does not recover, the controller needs repairing. If the display recovers, check for noise interference.
E333	Abnormal A/D converter	OFF (2mA max.)	OFF	Turn power off and then on again. If the display does not recover, the controller needs repairing. If the display recovers, check for noise interference.
RErr	Abnormal calibration data Displayed for 3 s at power on.	Normal operation (Accuracy not guaranteed)		Re-calibration is required.

※ If the input value exceeds the display limit (-1999 to 9999), though it is within the control range, EEEE will be displayed under -1999 and 3333 above 9999. Under these conditions, control output and alarm output will operate normally.

**■ SWITCH SETTINGS**

Press the hook at the bottom of front panel and draw out the internal mechanism from the case. Do not touch the internal terminals. If the internal terminals are deformed, the case will not fit any more.



**ALM2 ALM1 Alarm mode selectors 1/2**

No.	Alarm mode	Alarm output operation	
		$X \geq 0$	$X < 0$
0	No alarm	Output OFF	
1	Upper and lower limit alarm	ON	Continuously ON
2	Upper limit alarm	ON	Continuously ON
3	Lower limit alarm	ON	Continuously ON
4	Upper and lower limit range alarm	OFF	Continuously OFF
5	Upper and lower limit alarm with standby sequence	OFF	Continuously OFF
6	Upper limit alarm with standby sequence	OFF	Continuously OFF
7	Lower limit alarm with standby sequence	OFF	Continuously OFF
8	Absolute value upper limit alarm	ON	Continuously ON
9	Absolute value lower limit alarm	ON	Continuously ON

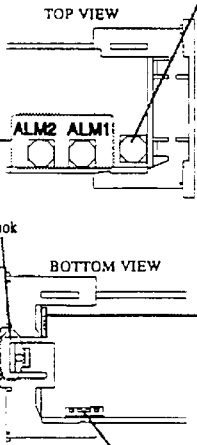

**INPUT Input type selector**

No.	Input type	Setting range	
		°C	°F
0, 8	JPt100	-199.9 to 650.0	-199.9 to 999.9
1, 9	Pt100	-199.9 to 650.0	-199.9 to 999.9
2	K	-200 to 1300	-300 to 2300
3	J	-100 to 850	-100 to 1500
4	T	-199.9 to 400.0	-199.9 to 700.0
5	L	-100 to 850	-100 to 1500
6	U	-199.9 to 400.0	-199.9 to 700.0
7	N	-200 to 1300	-300 to 2300

JPt100 : 139.16 Ω at 100 °C  
Pt100 : 138.50 Ω at 100 °C

**How to change the temperature unit to °F**

- After completing all the other switch settings, turn on Function Selector No.4.
- Insert the internal mechanism into case and turn power on.
- The display will show:  $\frac{d-U}{SP} \rightarrow F$ . Press Up key once to change the temperature unit to °F. The display will show F.
- Wait for 2 s or more after the display has changed to F, and then turn power off.
- Draw out the internal mechanism from the case and turn off Function Selector No.4. Then insert the internal mechanism into case and turn power on.

**PROTECT Key protection switch**

SP Mode	Disabled keys
SP	Set values other than Set Point are protected. Level key is disabled. Up and Down keys are disabled except for Set Point setting.
ALL	No key is disabled. Display, Level, Up, and Down keys are enabled.
ALL	All the set values are protected. Level, Up, and Down keys are disabled.

**FUNCTION Function Selector**

No.	1	2	3	4
Output operation	Normal (cool) ON	Reverse (Heat) OFF	CN/OFF	ON ※
Control mode	Advanced PID	Advanced PID with fuzzy self-tuning	OFF	OFF
Normally	OFF	OFF	OFF	OFF
Factory setting	OFF	OFF	OFF	OFF

※ ON or OFF: ON/OFF control when No.2 is turned on, regardless of No.3 setting.

**■ ADVANCED PID WITH FUZZY SELF-TUNING**

In Fuzzy self-tuning, disturbance on the process value is monitored and PID constants are tuned to the value optimum for the controlled system while the control operation is being carried out.